

PACKAGE CONTENTS

* 1x PoE switch	* 1x Quick Installation Guide
* 1x T25 L-wrench	

⚠ IMPORTANT:

1. Install the PoE switch in a ventilated and dry place that is free of electromagnetic source, vibration, moisture, and dust.
2. Make sure the ventilation openings on the switch are not blocked.
3. Use CAT5 or 5e UTP/STP cables.
4. AC input (100~240V/AC, 50~60Hz).
5. IP67 rated housing
6. Although housing is IP67 rating , this is not suitable for water jets.

CONNECTION

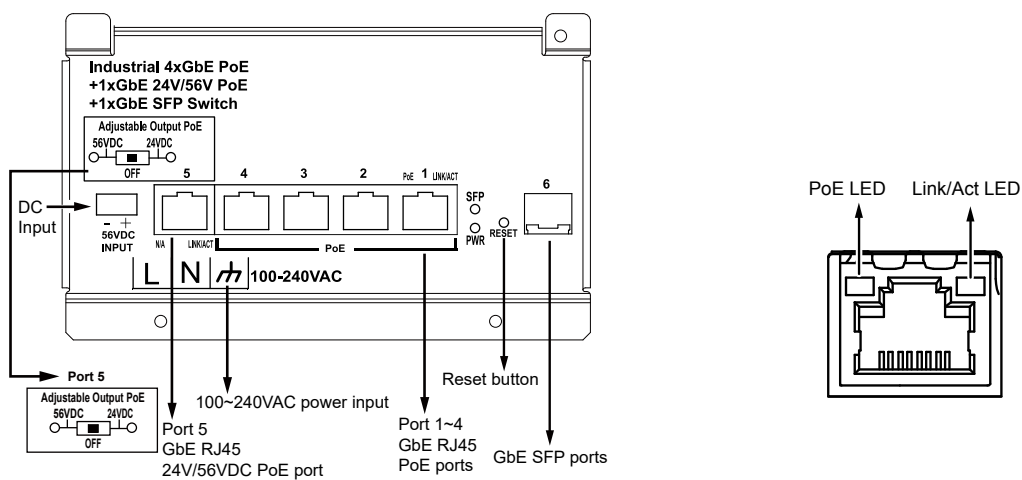

⚠ IMPORTANT:

The cabinet must be grounded using a ground wire between the ground screw and earth ground.

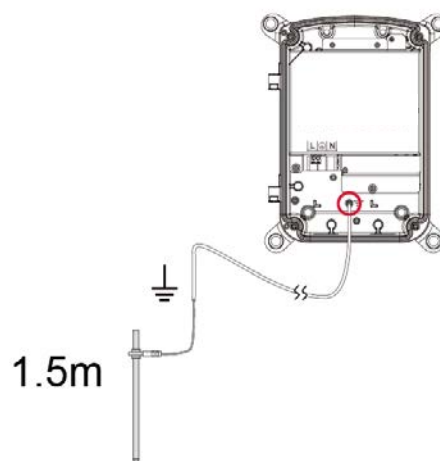

LED DEFINITIONS

Power	Orange ON	Power is on and normal.
	Orange Off	Power is off.
Link/Act	Green ON	Ethernet port is connected.
	Green Off	No connection.
	Green blinking	Data is being transmitted or received.
PoE	Orange ON	Port is linked to a powered device.
	Orange Off	No device is connected.
	Orange blinking	Abnormal power supply is detected.

INSTALLATION

Use the included M10 hex socket screws to secure the power box to a pole-mount or corner mount bracket.

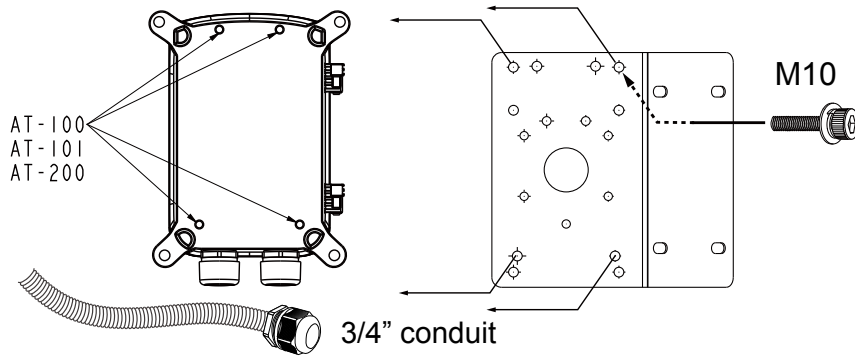

The mounting hole definition is illustrated below. The same mounting hole pattern apply to all pole-mount and corner-mount brackets.

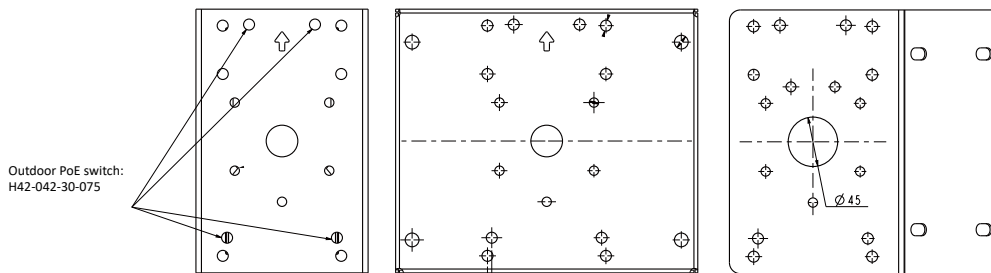

ASSEMBLE CABLE GLANDS

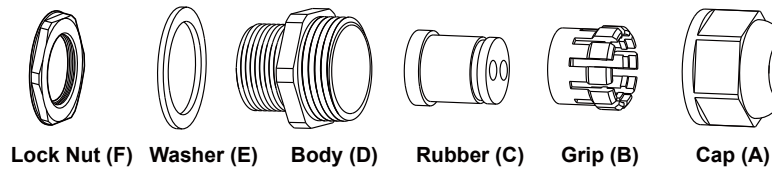

1. Thread the Cat5e/6 cable through the cap(A) & grip(B)
2. Split rubber(C), rubber have one sizes for meet 4.5~6.5mm Cat5e/6 cable.
3. Fit the split rubber(C) over the Cat5e/6 cable
4. Thread the Cat5e/6 cable through the body(D)
5. Assemble the washer to the body.
6. Mount the nut to the assemblage.
7. Tighten the cap and the body together as the illustration shows.
8. Tighten the whole assemblage to the full. See the illustration.

All specifications are subject to change without notice.
Copyright © 2023 AETEK INC. All rights reserved.