

Model	Description
H51-044-30-150	4xGbE 30W PoE+2xGbE SFP+ 2xGbE RJ45 100-240 VAC Input
H51-044-90-250	4xGbE 90W PoH PoE+2xGbE SFP+ 2xGbE RJ45 100-240 VAC Input
H51-044-91-250	4xGbE 90W bt PoE+2xGbE SFP+ 2xGbE RJ45 100-240 VAC Input
H51-084-30-250	8xGbE 30W PoE+4xGbE SFP 100-240 VAC Input

Model	Description
H51-044-30-DC	4xGbE 30W PoE+2xGbE SFP+ 2xGbE RJ45 12-56 VDC Input
H51-044-90-DC	4xGbE 90W PoH PoE+2xGbE SFP+ 2xGbE RJ45 12-56 VDC Input
H51-044-91-DC	4xGbE 90W bt PoE+2xGbE SFP+ 2xGbE RJ45 12-56 VDC Input
H51-084-30-DC	8xGbE 30W PoE+4xGbE SFP 12-56 VDC Input

INTRODUCTION

The H51 series is a 4/8 port 10/100/1000BaseT at PoE or PoH/bt switch capable of feeding 15.4/30W or 15.4/30//60/90W (54V max. per port) power to Power over Ethernet (PoE) devices. It comes with another 2x GbE TP port + 2xGbE SFP port or 4xGbE SFP port. The switch is capable of a total of 120W/240 Watts PoE power budget.

PACKAGE CONTENTS

* 1x PoE switch	* 1x Quick Installation Guide	* 1x Console cable
* 1x T25 L-wrench, 4x wall anchors		

⚠ IMPORTANT:

1. Install the PoE switch in a ventilated and dry place that is free of electromagnetic source, vibration, moisture, and dust.
2. Make sure the ventilation openings on the switch are not blocked.
3. Use CAT5 or 5e UTP/STP cables.
4. AC input (100~240V/AC, 50~60Hz), for a max. consumption of 150W/250W.
5. Digital output (relay): ON/OFF, support 24VDC/1A. Digital input: level 0(Low), level 1(High).

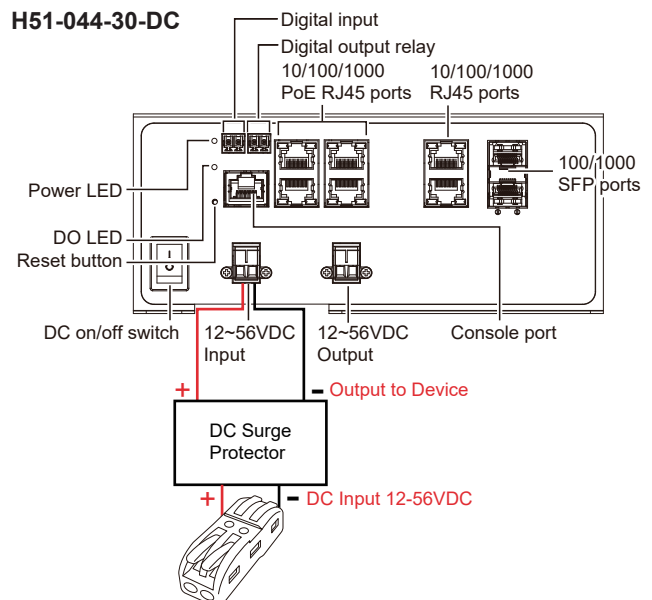
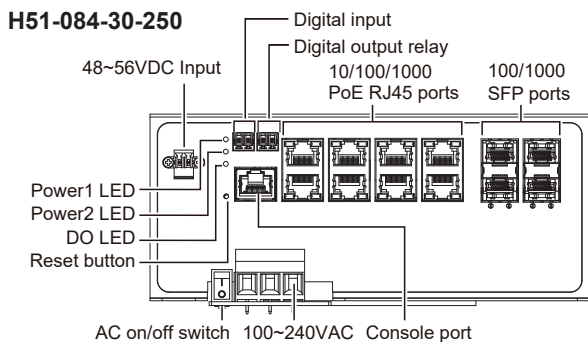
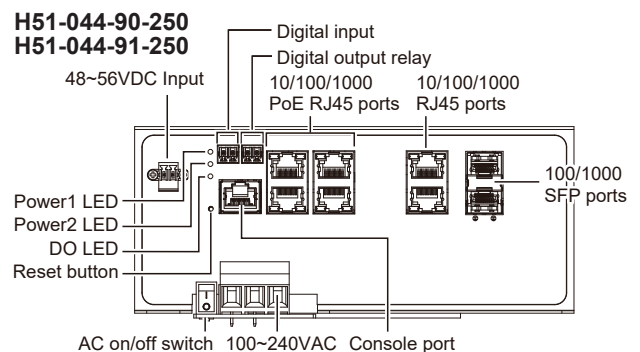
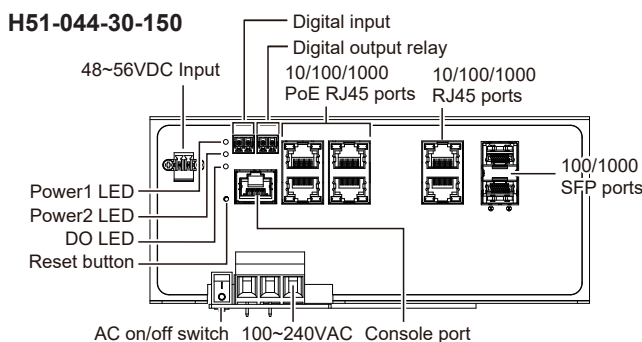

H51-044-90-DC
H51-044-91-DC

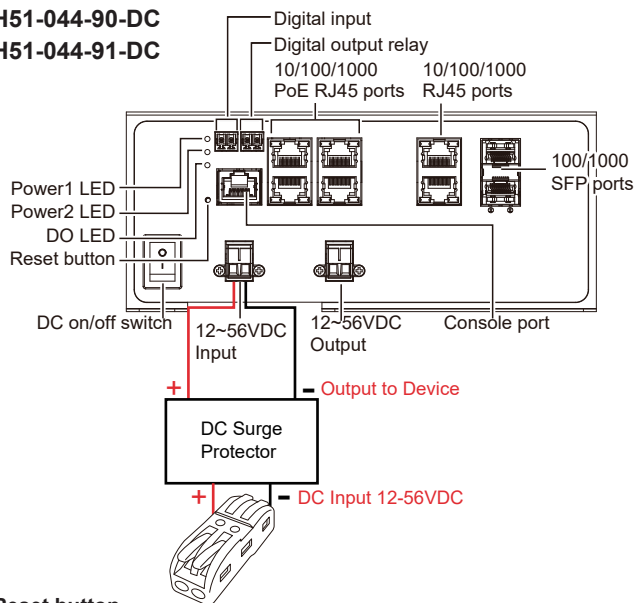

H51-084-30-DC

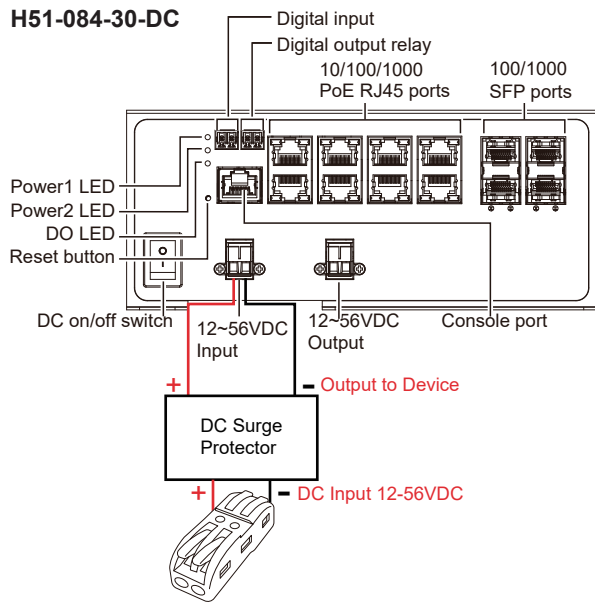

Reset button

Task	Method	SYS LED Behavior	Port Status LED Behavior
Reset	Press 2 ~ 7 seconds	Blinking Green	All LEDs Off.
Restore Defaults	Press 7 ~ 12 seconds	Blinking Green	All LEDs On.

Port Status LEDs

LED	Color	State	Description
RJ45 Ports Up (PoE)	Amber	On	The port is enabled and supplying power to connected device.
		Off	The port has no active connection, or it is not connected to a PoE PD device. Otherwise, the port may have been disabled through the switch user interface.
RJ45 Ports Down (LAN)	Green	On	The port is enabled and established a link to connected device.
		Blinking	The port is transmitting/receiving packets.
		Off	The port has no active network connection, or it has no established link to connected device. Otherwise, the port may have been disabled through the switch user interface.
SFP Ports	Green	On	The port is enabled and established a link to connected device,
		Blinking	The port is transmitting/receiving packets.
		Off	The port has no active network connection, or it has no established link to connected device. Otherwise, the port may have been disabled through the switch user interface.

DO LED

LED	Color	State	Description
System	Yellow	On	DO ON
		Off	DO OFF

DEFAULTS

IP Address	192.168.1.1
Subnet Mask	255.255.255.0
User Name	admin
Password	admin

AC Power Cable Spec.

Wire Size	10~18AWG
Wire Strip Length	8mm

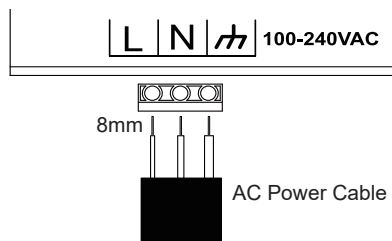

DC Power Cable Spec.

Wire Size	10~18AWG
Wire Strip Length	8mm

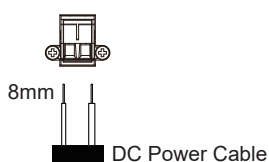

Power LEDs

LED	Color	State	Description
Power1	Green	On	Powered on correctly.
		Off	Not receiving power from power1.
Power2	Green	On	Powered on correctly.
		Off	Not receiving power from power1.

Console Port Defaults

Baud rate	115200
Stop bits	1
Data bits	8
Parity	N
Flow control	none

DI/DO Connection Diagram

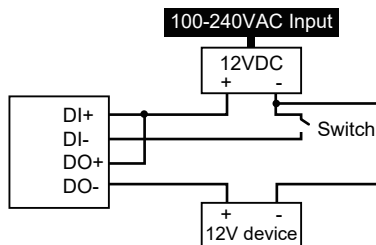

DI/DO Connection Diagram w/ AC or DC Relay

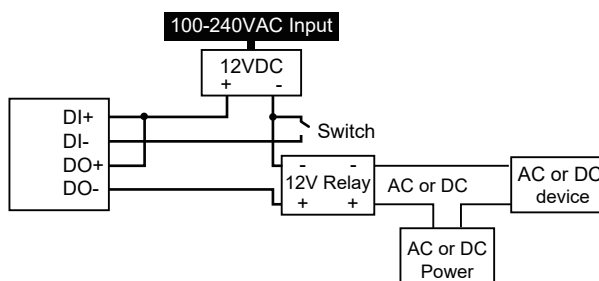

Outdoor PoE switch:
 H51-044-30-150
 H51-044-90-250
 H51-044-91-250
 H51-084-30-250
 H51-044-30-DC
 H51-044-90-DC
 H51-044-91-DC
 H51-084-30-DC

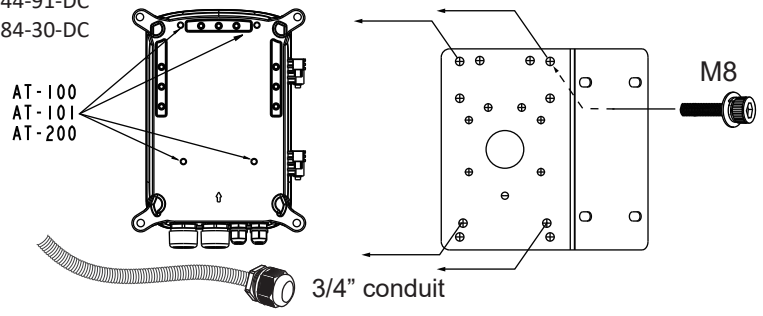

The cabinet must be grounded using a ground wire between the ground screw and earth ground.

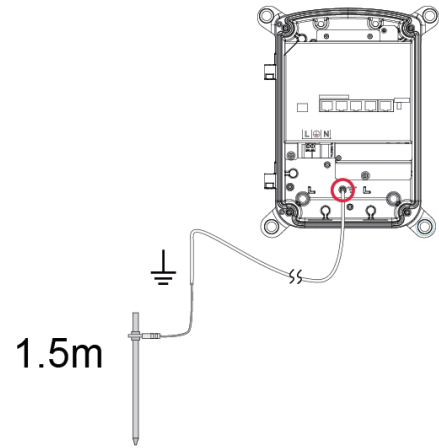

Assemble Cable Glands

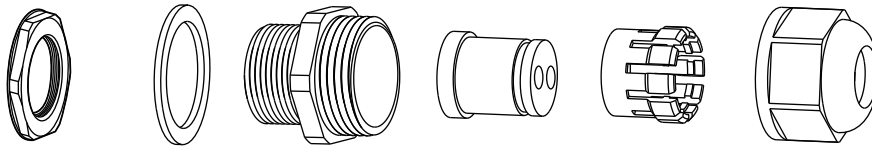

Lock Nut (F) Washer (E) Body (D) Rubber (C) Grip (B) Cap (A)

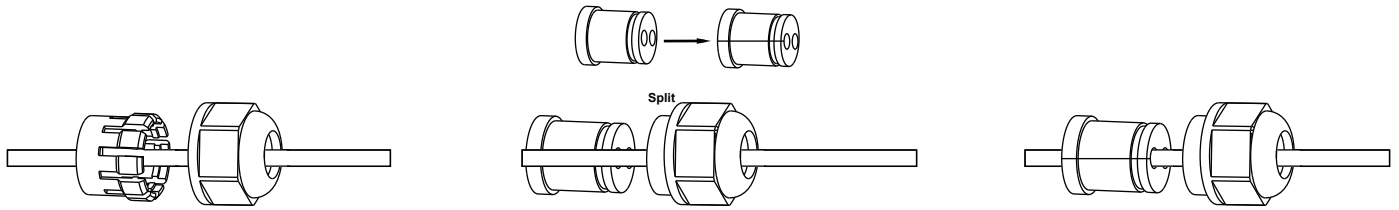

1. Thread the Cat5e/6 cable through the cap(A) & grip(B)
2. Split rubber(C), rubber have one sizes for meet 5.4~6mm Cat5e/6 cable.
3. Fit the split rubber(C) over the Cat5e/6 cable

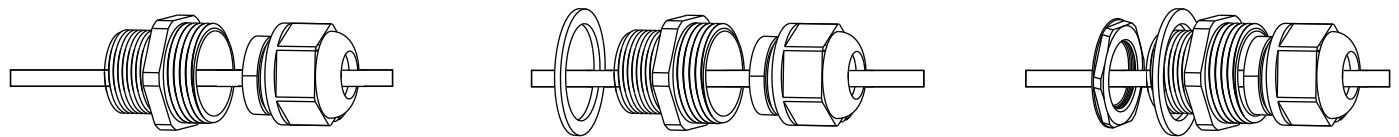

4. Thread the Cat5e/6 cable through the body(D)
5. Assemble the washer to the body.
6. Mount the nut to the assemblage.

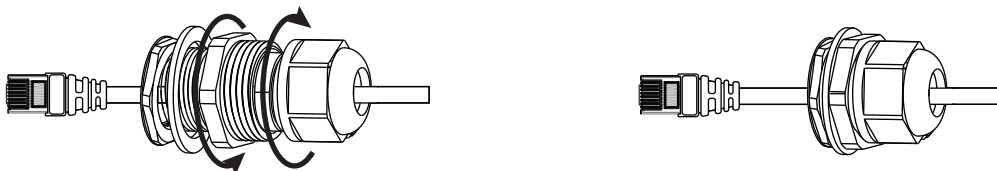

7. Tighten the cap and the body together as the illustration shows.
8. Tighten the whole assemblage to the full. See the illustration.

All specifications are subject to change without notice.
 Copyright © 2024 AETEK INC. All rights reserved.

AETEK INC.
 6F, No.192-1, Lien-Cheng Rd., Chung-Ho, New Taipei City, 235, Taiwan, R.O.C.
 | T: +8862-82452822 | W: www.aetektec.com | E: sales@aetektec.com