



D62-040-30-BT L2 PRO Gigabit PoE Switch

Quick Installation Guide

P/N: 5019061801

Model	Description
D62-040-30-BT	4xGbE 30W PoE + 1xGbE bt PoE PD RJ45 + 2x24V DC output + 2x12V DC output Managed Switch

INTRODUCTION

The D62-040-30-BT is a 4 port 10/100/1000BaseT at PoE switch capable of feeding 15.4/30W (54Vmax. per port) power to Power over Ethernet (PoE) devices.

PACKAGE CONTENTS

* 1x PoE switch	* 1x Quick Installation Guide	* 6 x 2-pin terminal block
* 1x DB9F-RJ45 console cable	* 1x DIN rail bracket	

⚠ IMPORTANT

1. To prevent potential damage, ensure that all 12V DC, 24V DC, and Digital Input/Output (DI/DO) devices are properly connected before applying or turning on the DC input power. Connecting these devices after the power is on may result in malfunction or damage.
2. Install the converter in a ventilated and dry place that is free of electromagnetic source, vibration, moisture, and dust.
3. Make sure the ventilation openings on the converter are not blocked.
4. bt PoE input.
5. Digital output : ON/OFF, support max. 24V DC/0.1A. Digital input: level 0(open), level 1(Close to GND).

CONNECTION

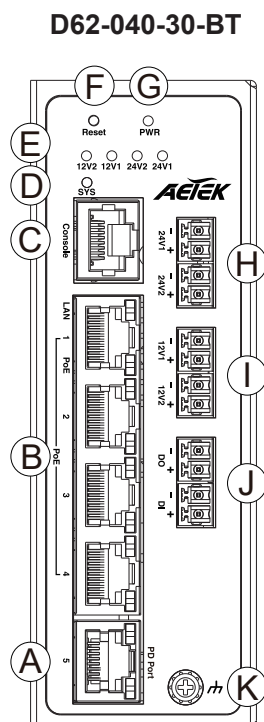
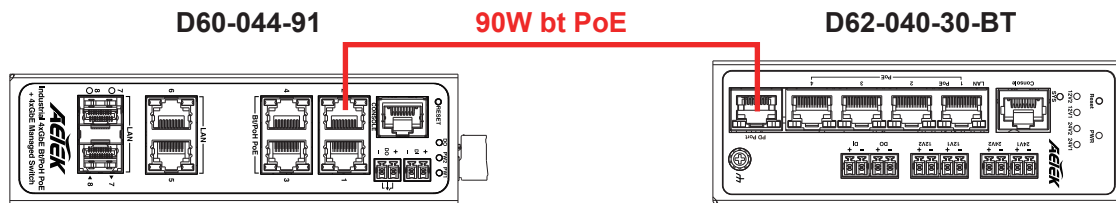

- (A) 10/100/1000 bt PoE PD RJ45 port
- (B) 10/100/1000 PoE RJ45 ports
- (C) Console port
- (D) SYS LED
- (E) 12V2 / 12V1 / 24V2 / 24V1 LED
- (F) Reset button
- (G) Power LED
- (H) 24V DC output ports
- (I) 12V DC output ports
- (J) DI / DO ports
- (K) GND

DEFAULTS	
IP Address	192.168.1.1
Subnet Mask	255.255.255.0
User Name	admin
Password	admin

Power LEDs

LED	Color	State	Description
Power	Amber	On	Powered on correctly.
		Off	Not receiving power from power1.

Console Port Defaults

Baud rate	115200
Stop bits	1
Data bits	8
Parity	N
Flow control	none

Port Status LEDs

LED	Color	State	Description
RJ45 Ports Up (PoE)	Amber	On	The port is enabled and supplying power to connected device.
		Off	The port has no active connection, or it is not connected to a PoE PD device. Otherwise, the port may have been disabled through the switch user interface.
RJ45 Ports Down (LAN)	Green	On	The port is enabled and established a link to connected device.
		Blinking	The port is transmitting/receiving packets.
		Off	The port has no active network connection, or it has no established link to connected device. Otherwise, the port may have been disabled through the switch user interface.

Reset button

Task	Method	SYS LED Behavior	Port Status LED Behavior
Reset	Press 2 ~ 7 seconds	Blinking Green	All LEDs Off.
Restore Defaults	Press 7 ~ 12 seconds	Blinking Green	All LEDs On.

DI/DO Connection Diagram

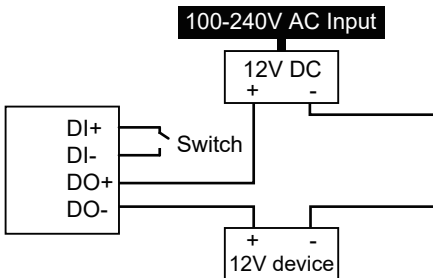

DI/DO Connection Diagram w/ AC or DC Relay

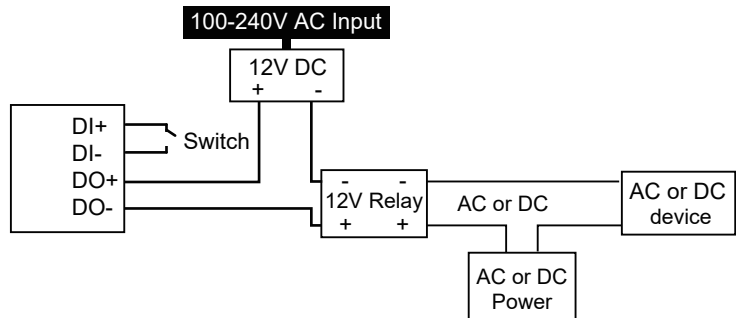

DIN Rail Installation

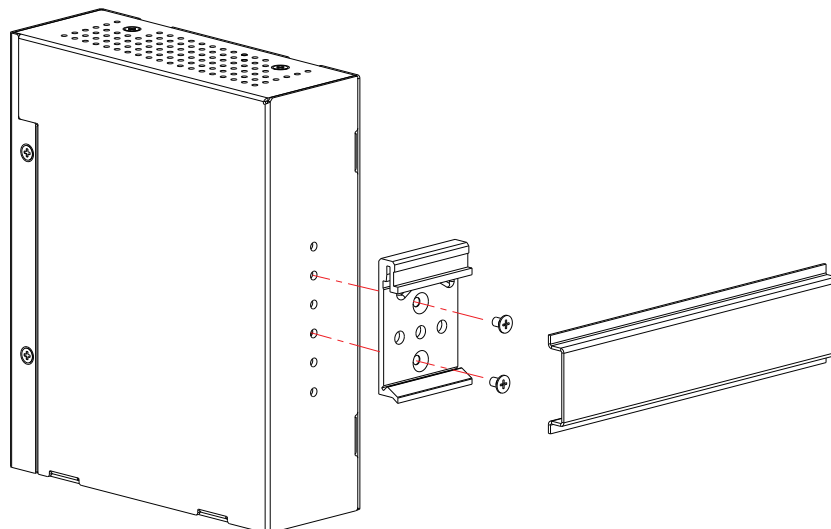

Ground loops

Do not connect the power supply negative or Battery negative terminal of our device to the chassis or earth exclusively. This connection could cause ground loops. For example, if the Battery negative and power supply negative terminal are connected to the chassis or earth, it forms a ground loop, therefore unwanted current could flow through a device PCB ground and may cause damage.

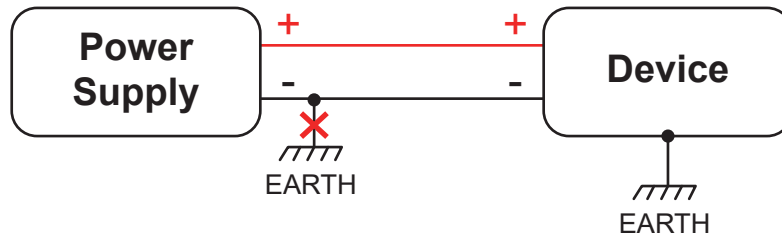

⚠ Power on

- ▶ Power on: First insert the power terminal of the power cable into the power port of the device, then plug in the power plug and power on. After the Switch is started, the Switch automatically initializes. If all port indicators are on and then off, the system is successfully reset, the power LED indicator will always stay on.
- ▶ Power off operation: Unplug the power plug first, and then remove the wiring part of the terminal. Please pay attention to the above operation sequence.

⚠ Warning:

Do not operate the device with input voltage approaching or exceeding 57V DC. Doing so may trigger protective shutdown of PoE and DC outputs.