

Model	Description
D62-084-30-DC	8xGbE 30W PoE + 2xGbE SFP + 2xGbE RJ45 + 4x24VDC output + 2x12VDC output w/ 12-48 VDC Input Managed Switch

INTRODUCTION

The D62-084-30-DC is a 8 port 10/100/1000BaseT at PoE switch capable of feeding 15.4/30W (54Vmax. per port) power to Power over Ethernet (PoE) devices. It comes with another 1xGbE RJ45 port or 2xGbE RJ45 ports+2xGbE SFP ports.

PACKAGE CONTENTS

* 1x PoE switch	* 1x Quick Installation Guide	* 1x 4-pin terminal block
* 1x DB9F-RJ45 console cable	* 1x DIN rail bracket	* 8x 2-pin terminal block

⚠ IMPORTANT:

- To prevent potential damage, ensure that all 12VDC, 24VDC, and Digital Input/Output (DI/DO) devices are properly connected before applying or turning on the DC input power. Connecting these devices after the power is on may result in malfunction or damage.
- Install the converter in a ventilated and dry place that is free of electromagnetic source, vibration, moisture, and dust.
- Make sure the ventilation openings on the converter are not blocked.
- Use fiber optic cables and transceiver compliant with the following: Multi-mode: 50/125um, 62.5/125um, 850nm; Single-mode): 9/125um, 1310nm.
- DC input (12~48VDC). Follow the printed polarity for V+, V-, and Ground.
- Digital output (relay): ON/OFF, support 24V DC/1A. Digital input: level 0(5~12 Volts (10mA)), level 1(0~1 Volts).

CONNECTION

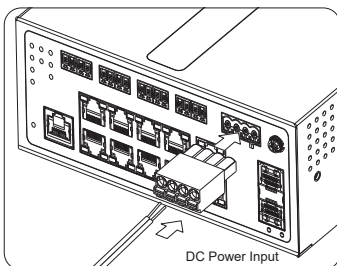

- Pull out the 4-pin terminal block.
- Connect power wires to V+, and V-.
- Connect SFP transceivers to the fiber port.
- install the 4-pin terminal block.

DC Power Cable Spec.

Wire Size	12~24AWG
Wire Strip Length	10mm

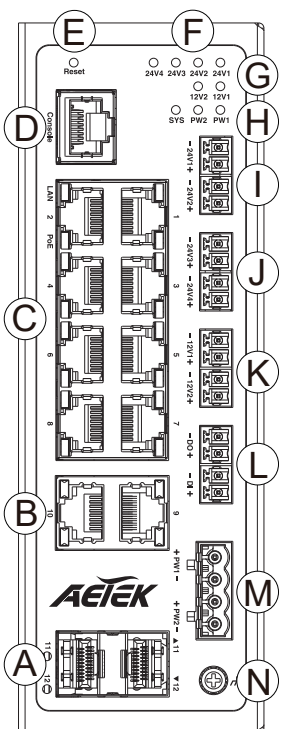
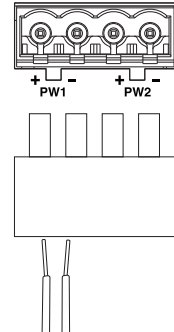

- (A) 100/1000 SFP ports
- (B) 10/100/1000 RJ45 ports
- (C) 10/100/1000 PoE RJ45 ports
- (D) Console port
- (E) Reset button
- (F) 24V4 / 24V3 / 24V2 / 24V1 LED
- (G) 12V2 / 12V1 LED
- (H) Power2 / Power1 / SYS LED
- (I) 24VDC output ports
- (J) 24VDC output ports
- (K) 12VDC output ports
- (L) DI / DO ports
- (M) 12~48VDC Input
- (N) GND

DEFAULTS

IP Address	192.168.1.1
Subnet Mask	255.255.255.0
User Name	admin
Password	admin

Power LEDs

LED	Color	State	Description
Power1	Green	On	Powered on correctly.
		Off	Not receiving power from power1.
Power2	Green	On	Powered on correctly.
		Off	Not receiving power from power2.

Console Port Defaults

Baud rate	115200
Stop bits	1
Data bits	8
Parity	N
Flow control	none

Port Status LEDs

LED	Color	State	Description
RJ45 Ports (PoE)	Amber	On	The port is enabled and supplying power to connected device.
	-	Off	The port has no active connection, or it is not connected to a PoE PD device. Otherwise, the port may have been disabled through the switch user interface.
RJ45 Ports (LAN)	Green	On	The port is enabled and established a link to connected device.
	Green	Blinking	The port is transmitting/receiving packets.
	-	Off	The port has no active network connection, or it has no established link to connected device. Otherwise, the port may have been disabled through the switch user interface.
SFP Ports	Green	On	The port is enabled and supplying power to connected device.
	Green	Blinking	The port is transmitting/receiving packets.
	-	Off	The port has no active network connection, or it has no established link to connected device. Otherwise, the port may have been disabled through the switch user interface.

Reset button

Task	Method	SYS LED Behavior	Port Status LED Behavior
Reset	Press 2 ~ 7 seconds	Blinking Green	All LEDs Off.
Restore Defaults	Press 7 ~ 12 seconds	Blinking Green	All LEDs On.

Ground loops

Do not connect the power supply negative or Battery negative terminal of our device to the chassis or earth exclusively. This connection could cause ground loops. For example, if the Battery negative and power supply negative terminal are connected to the chassis or earth, it forms a ground loop, therefore unwanted current could flow through a device PCB ground and may cause damage.

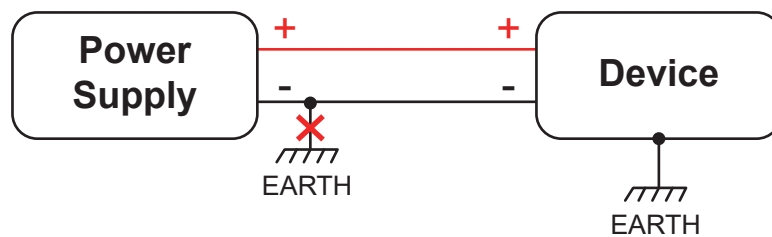

⚠ Caution — PoE & DC Output Port Wiring

Each 12 V / 24 V DC output port provides a dedicated positive (+) and negative (-) terminal pair. Incorrect wiring may create a **ground loop**, causing equipment damage, malfunction, or electric hazard.

Each DC output port must only power **one device**. Always connect both the positive (+) and negative (-) terminals of the **same port** to a single device to prevent ground loop issues.

Do not mix terminals across different DC output ports, and **do not** connect multiple DC output ports to the same device. Either configuration creates a **ground loop**.

Do not connect both a **DC output port** and a **PoE port** to the same device simultaneously. Powering a device through both interfaces creates a **ground loop**. If no non-PoE RJ45 port is available, use an SFP port with the optional **SFP-ITX-X1** (SFP to RJ45) transceiver instead.

If a DC-powered device (e.g., LTE router) also requires a LAN connection, connect it to a **non-PoE RJ45 port only**. **Do not use a PoE port**, as PoE ports continuously transmit detection signals that can interact with DC ground, causing a **ground loop**.

PoE & DC Output Port Wiring

✔ CORRECT — EACH PORT POWERS ONE DEVICE

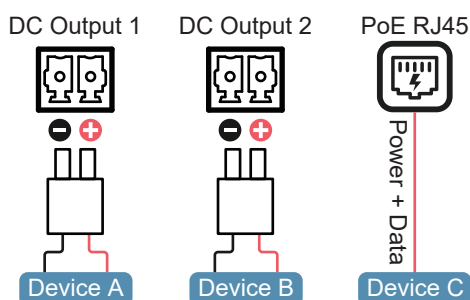

✗ INCORRECT

Case 1 — Cross-port DC Wiring

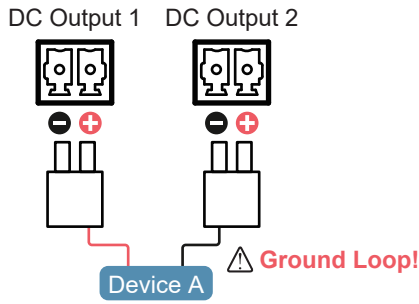

Case 2 — Multiple DC Output Ports to Same Device

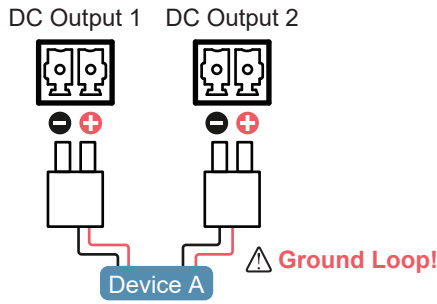

Case 3 — PoE & DC Output on Same Device

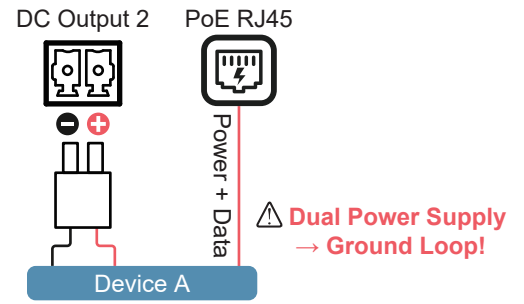

LAN Connection for DC-Powered Devices

✓ CORRECT — LAN VIA NON-POE RJ45 PORT

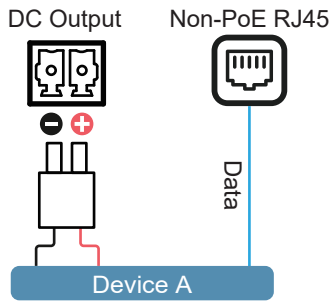

✗ INCORRECT

Case 4 — LAN via PoE Port

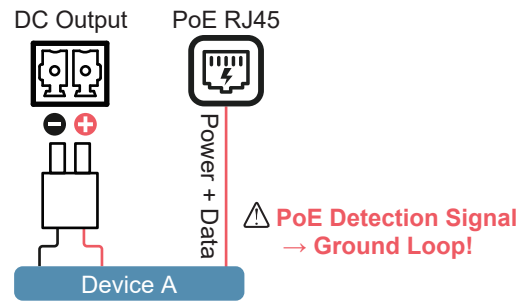

⚠ Power on

- ▶ Power on: First insert the power terminal of the power cable into the power port of the device, then plug in the power plug and power on. After the Switch is started, the Switch automatically initializes. If all port indicators are on and then off, the system is successfully reset, the power LED indicator will always stay on.
- ▶ Power off operation: Unplug the power plug first, and then remove the wiring part of the terminal. Please pay attention to the above operation sequence.

⚠ Warning:

Do not operate the device with input voltage approaching or exceeding 57V DC. Doing so may trigger protective shutdown of PoE and DC outputs.

DI/DO Connection

DI/DO Connection Diagram

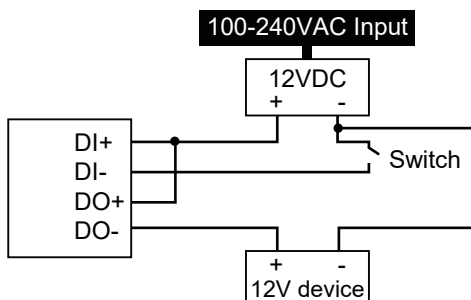

DI/DO Connection Diagram w/ AC or DC Relay

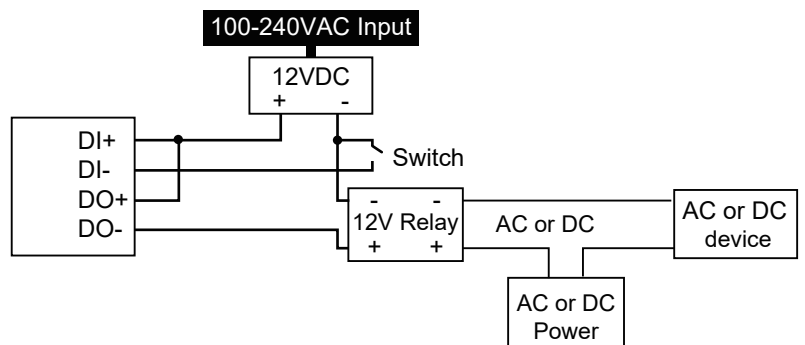

Installation

DIN Rail Installation

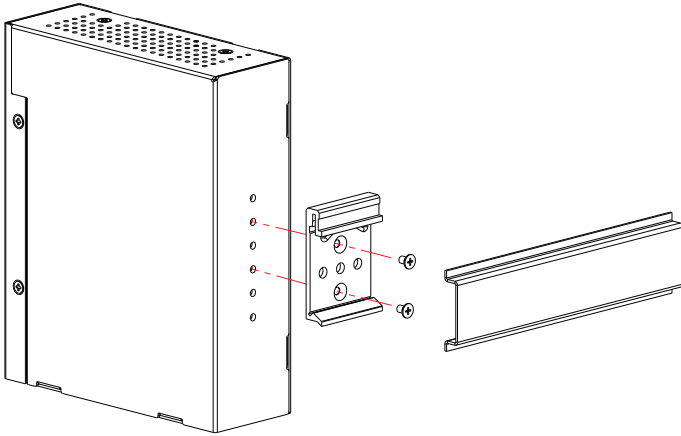

Wall Mount Installation

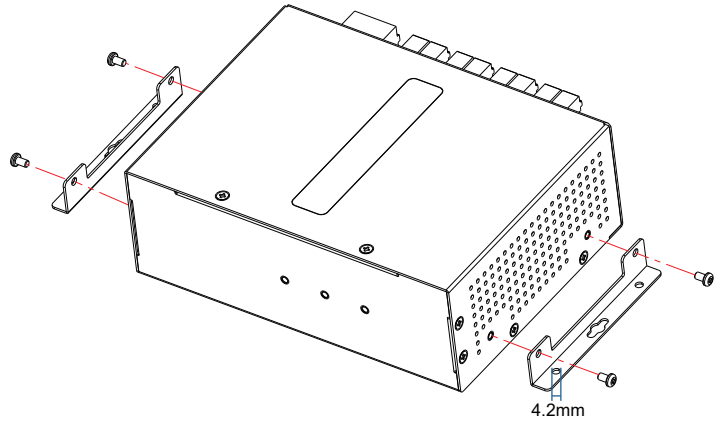

All specifications are subject to change without notice.
Copyright © 2026 AETEK INC. All rights reserved.

AETEK INC.
6F, No.192-1, Lien-Cheng Rd., Chung-Ho, New Taipei City, 235, Taiwan, R.O.C.
| T: +8862-82452822 | W: www.aetektec.com | E: sales@aetektec.com