

### PACKAGE CONTENTS

* 1x Fiber Splice Tray	* 1x Quick Installation Guide	* 1x M4x6mm screw
------------------------	-------------------------------	-------------------

Note : AT-302 only for H42-042-30-075, H40-022-90-120, H40-022-91-120, H40-022-90-120-A, H40-022-91-120-A, H40-042-30-075, H60-022-90-120, H60-022-90-120-B, H60-022-90-DC, H40-022-90-DC use.

### Installation

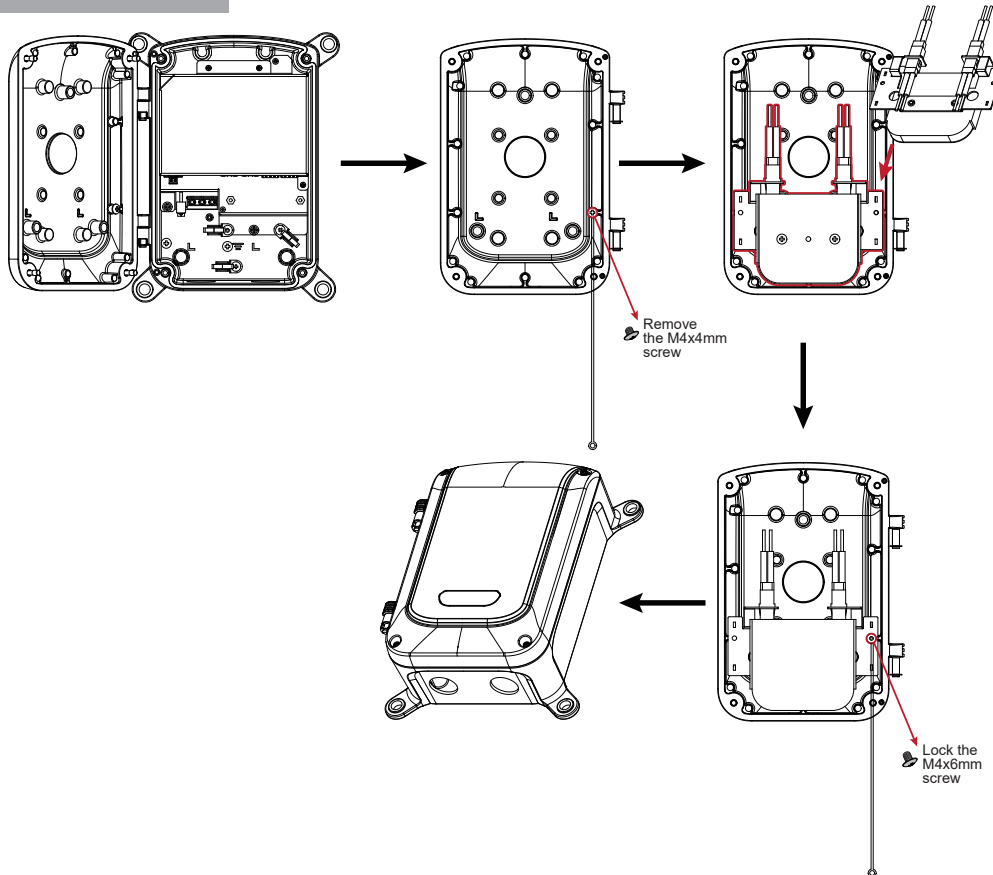

1. Open H42-042-30-075, H40-022-90-120, H40-022-91-120, H40-022-90-120-A, H40-022-91-120-A, H40-042-30-075, H60-022-90-120, H60-022-90-120-B, H60-022-90-DC, H40-022-90-DC by loosening the screws on the top casing.
2. Remove the M4x4mm screw on the H42-042-30-075, H40-022-90-120, H40-022-91-120, H40-022-90-120-A, H40-022-91-120-A, H40-042-30-075, H60-022-90-120, H60-022-90-120-B, H60-022-90-DC, H40-022-90-DC top casing
3. Put the AT-302 on the H42-042-30-075, H40-022-90-120, H40-022-91-120, H40-022-90-120-A, H40-022-91-120-A, H40-042-30-075, H60-022-90-120, H60-022-90-120-B, H60-022-90-DC, H40-022-90-DC top casing
4. Make sure the AT-302 is placed correctly and then put in the M4x6mm screw to fasten it.
5. After the installation, close the top casing and install the H42-042-30-075, H40-022-90-120, H40-022-91-120, H40-022-90-120-A, H40-022-91-120-A, H40-042-30-075, H60-022-90-120, H60-022-90-120-B, H60-022-90-DC, H40-022-90-DC on a wall, pole or corner with the related accessories (AT-100, AT-101 or AT-200)

Fiber Tray

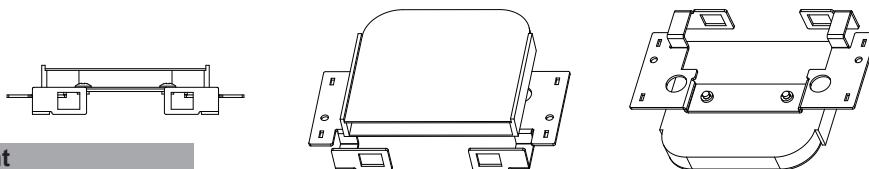

### Tool Requirement

1. Cable stripper and cutters
2. Fusion splice machine and related tools
3. Single SC to single SC, single SC to single LC, single LC to single LC or dual LC to dual LC fiber adapters, screw and screw nut
4. single mode or multi mode fiber pigtail

### Warning

Always wear eye protection when working with optical fibers. Never look into the end of terminated or unterminated fibers. Laser radiation is invisible but can damage eye tissue. Never eat, drink or smoke when working with fibers. This could lead to ingestion of glass particles.

All specifications are subject to change without notice.  
Copyright © 2026 AETEK INC. All rights reserved.