

Model	Description
D60-044-30-V2	4xGbE 30W PoE+2xGbE SFP+ 2xGbE RJ45 48-56V DC Input
D60-044-90	4xGbE 90W PoH PoE+2xGbE SFP+ 2xGbE RJ45 48-56V DC Input
D60-044-91	4xGbE 90W bt PoE+2xGbE SFP+ 2xGbE RJ45 48-56V DC Input
D60-084-30-V2	8xGbE 30W PoE+4xGbE SFP 48-56V DC Input

Model	Description
D60-044-30-DC-V2	4xGbE 30W PoE+2xGbE SFP+ 2xGbE RJ45 12-56V DC Input
D60-044-90-DC	4xGbE 90W PoH PoE+2xGbE SFP+ 2xGbE RJ45 12-56V DC Input
D60-044-91-DC	4xGbE 90W bt PoE+2xGbE SFP+ 2xGbE RJ45 12-56V DC Input
D60-084-30-DC-V2	8xGbE 30W PoE+4xGbE SFP 12-56V DC Input

INTRODUCTION

The D60 / D60-V2 series is a 4/8 port 10/100/1000BaseT at PoE/ bt PoE switch capable of feeding 15.4/30W or 15.4/30/60/90W (54V/max. per port) power to Power over Ethernet (PoE) devices. It comes with another 2x GbE TP port + 2xGbE SFP port or 4xGbE SFP port.

PACKAGE CONTENTS

* 1x PoE switch	* 1x Quick Installation Guide	* 1x 4-pin terminal block
* 1x DB9F-RJ45 console cable	* 1x DIN rail bracket	* 2x 2-pin terminal block

IMPORTANT:

1. Install the converter in a ventilated and dry place that is free of electromagnetic source, vibration, moisture, and dust.
2. Make sure the ventilation openings on the converter are not blocked.
3. Use fiber optic cables and transceiver compliant with the following: Multi-mode: 50/125um, 62.5/125um, 850nm; Single-mode): 9/125um ,1310nm.
4. DC input (48~56V DC or 12~56V DC). Follow the printed polarity for V+, V-, and Ground.

CONNECTION

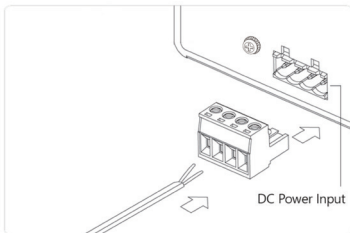

1. Pull out the 4-pin terminal block.
2. Connect power wires to V+, and V-.
3. Connect SFP transceivers to the fiber port.
4. install the 4-pin terminal block.

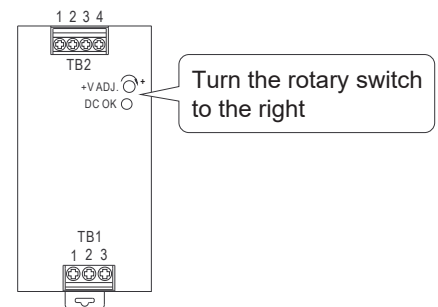

D60-044-30-V2

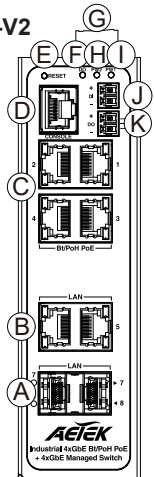

D60-044-90
D60-044-91

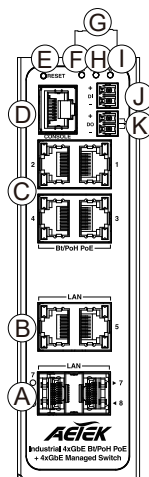

D60-084-30-V2

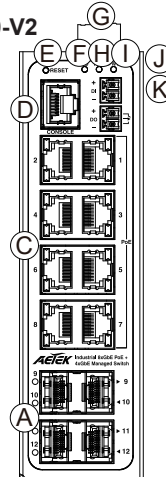

D60-044-30-DC-V2

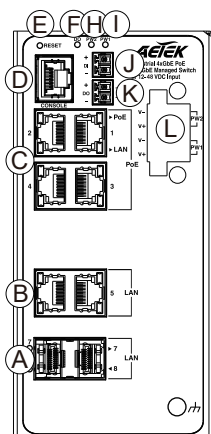

D60-044-90-DC
D60-044-91-DC

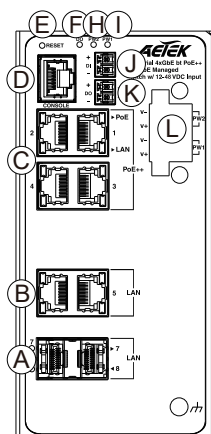

D60-084-30-DC-V2

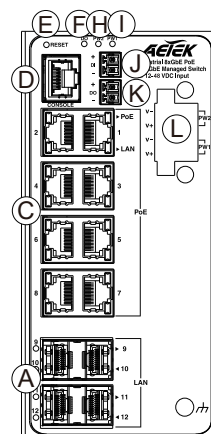

- Ⓐ 100/1000 SFP ports
- Ⓑ 10/100/1000 RJ45 ports
- Ⓒ 10/100/1000 PoE RJ45 ports
- Ⓓ Console port
- Ⓔ Reset button
- Ⓕ DO LED
- Ⓖ 48~56V DC Input
- Ⓗ Power2 LED
- Ⓘ Power1 LED
- Ⓙ Digital input
- Ⓚ Digital output
- Ⓛ 12~56V DC Input

DEFAULTS

IP Address	192.168.1.1
Subnet Mask	255.255.255.0
User Name	admin
Password	admin

DO LED

LED	Color	State	Description
System	Yellow	On	DO ON
		Off	DO OFF

Port Status LEDs

LED	Color	State	Description
RJ45 Ports Up (PoE)	Amber	On	The port is enabled and supplying power to connected device.
		Off	The port has no active connection, or it is not connected to a PoE PD device. Otherwise, the port may have been disabled through the switch user interface.
RJ45 Ports Down (LAN)	Green	On	The port is enabled and established a link to connected device.
		Blinking	The port is transmitting/receiving packets.
		Off	The port has no active network connection, or it has no established link to connected device. Otherwise, the port may have been disabled through the switch user interface.
SFP Ports	Green	On	The port is enabled and supplying power to connected device.
		Blinking	The port is transmitting/receiving packets.
		Off	The port has no active network connection, or it has no established link to connected device. Otherwise, the port may have been disabled through the switch user interface.

Reset button

Task	Method	SYS LED Behavior	Port Status LED Behavior
Reset	Press 2 ~ 7 seconds	Blinking Green	All LEDs Off.
Restore Defaults	Press 7 ~ 12 seconds	Blinking Green	All LEDs On.

D60-044-90 / D60-044-91 / D60-044-90-DC / D60-044-91-DC

Digital output (relay): ON/OFF, support 24V DC/1A. Digital input: level 0(5~12 Volts (10mA)), level 1(0~1 Volts).

DI/DO Connection Diagram

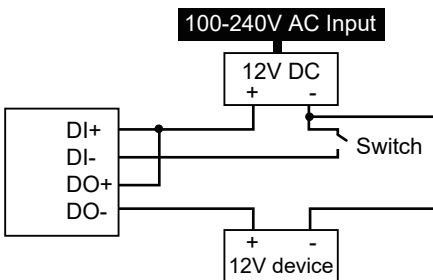

DI/DO Connection Diagram w/ AC or DC Relay

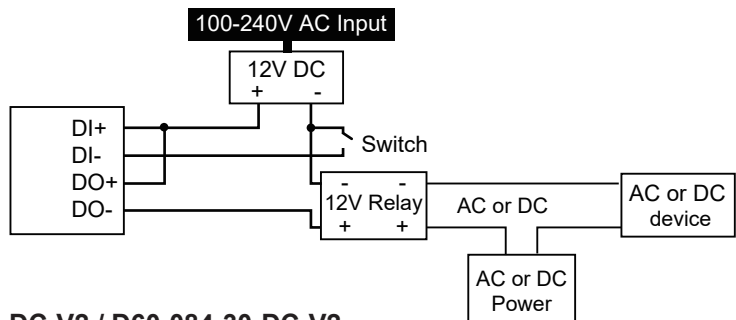

D60-044-30-V2 / D60-084-30-V2 / D60-044-30-DC-V2 / D60-084-30-DC-V2

Digital output (relay): ON/OFF, support support max. 24V DC/1A. Digital input: level 0(open), level 1(Close to GND).

DI/DO Connection Diagram

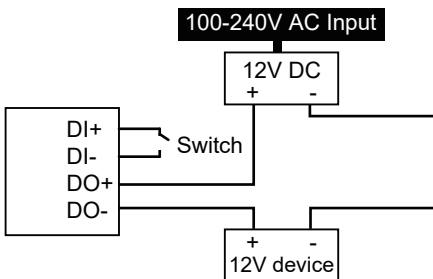

DI/DO Connection Diagram w/ AC or DC Relay

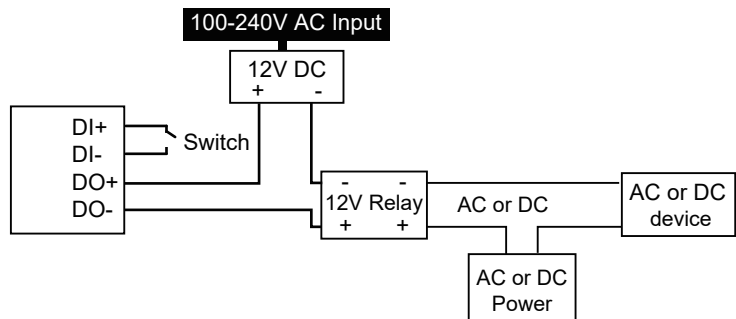

DIN Rail Installation

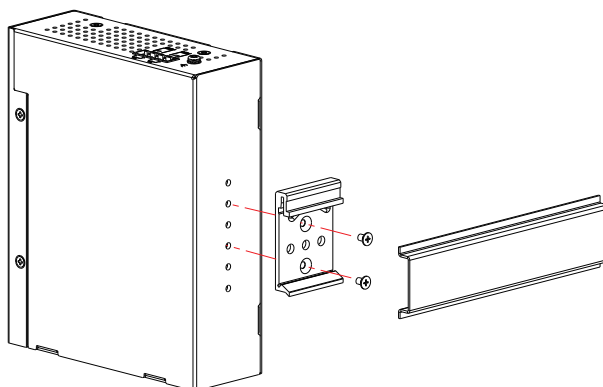

Power LEDs

LED	Color	State	Description
Power1	Green	On	Powered on correctly.
		Off	Not receiving power from power1.
Power2	Green	On	Powered on correctly.
		Off	Not receiving power from power2.

Console Port Defaults

Baud rate	115200
Stop bits	1
Data bits	8
Parity	N
Flow control	none

Ground loops

Do not connect the power supply negative or Battery negative terminal of our device to the chassis or earth exclusively. This connection could cause ground loops. For example, if the Battery negative and power supply negative terminal are connected to the chassis or earth, it forms a ground loop, therefore unwanted current could flow through a device PCB ground and may cause damage.

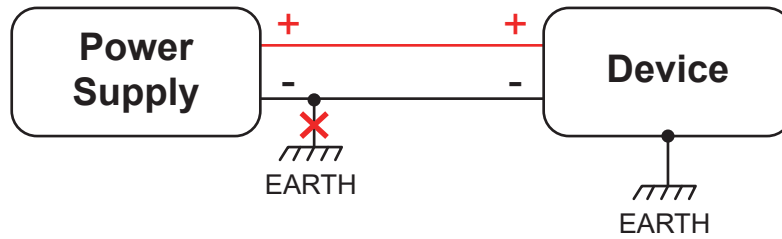

⚠ Power on

- ▶ Power on: First insert the power terminal of the power cable into the power port of the device, then plug in the power plug and power on. After the Switch is started, the Switch automatically initializes. If all port indicators are on and then off, the system is successfully reset, the power LED indicator will always stay on.
- ▶ Power off operation: Unplug the power plug first, and then remove the wiring part of the terminal. Please pay attention to the above operation sequence.

⚠ Warning:

Do not operate the device with input voltage approaching or exceeding 57V DC. Doing so may trigger protective shutdown of PoE and DC outputs.