

PACKAGE CONTENTS

* 1x Outdoor EPoC Adapter	* 1x Quick Installation Guide
* 1x Gray Rubber for 6~8mm coaxial cable	* 1x Black Rubber for 4.5~6.5mm coaxial cable

⚠ IMPORTANT:

1. Use CAT5e or CAT6 UTP/STP cables and RG6 coaxial cables.
2. Please avoid using low quality cables, which will seriously limit the cabling distance and power delivery.
3. Make sure the ventilation openings on the EPoC Adapter are not blocked.

⚠ INSTALLED LOCATION:

For further protection against water ingress and high temperature, it is recommended to locate the unit where possible:

- Horizontal installation
- Shaded from sunlight & rainfall

CONNECTION



PoE Budget : 8.3W@1,200m / 3,937ft over RG6
Total Camera bandwidth < 100Mbps

— PoE (Data + Power)
— Coax (Data + Power)

NOTE:

To disconnect a LAN cable, loosen the cable gland and pull the cable against the socket wall towards the side of the locking tab.

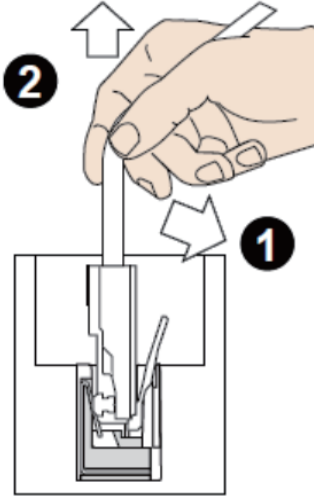

⚠ IMPORTANT:

NOTE:

The Outdoor EPoC Adapter & SD-301 Surge Protector must be grounded using a ground wire between the ground screw and earth ground.

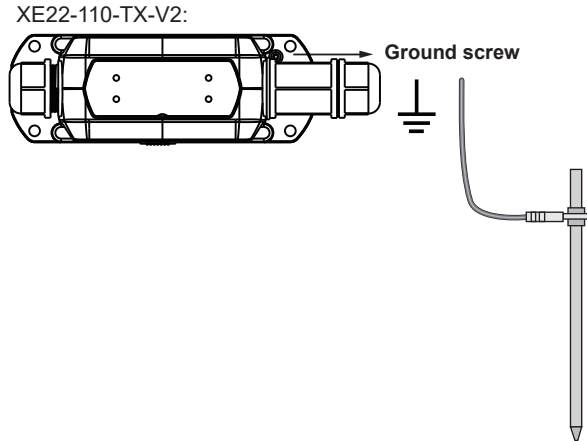

Distance/Power Chart

Length of Coaxial Cable	Power
300m	33.32W
500m	23.9W
800m	11.81W
1000m	8.7W
1200m	8.36W
1200m ~ 2400m	Data only (100Mbps)

NOTE:

1. The numbers comply using RG6 coaxial cables.
2. The length of network cable for camera connection is 1m CAT5e cable.
3. The power delivery will vary on the quality of coaxial cable due to resistance.

LEDs

LAN	Green ON	LAN: Data is connection
	Green flash	LAN: Data is being transmitted or received.
	OFF	No connection
PoE	Yellow ON	PoE output to PD device
	OFF	No PoE output to PD device
PWR	Green ON	EPoC Adapter power status
LINK	Green ON	Rx and Tx EPoC Adapter is connected.

DIP Switch

DIP#	On	Delivery PoE output to PD device
	Off	No PoE output to PD device

XE22-110-TX-V2:

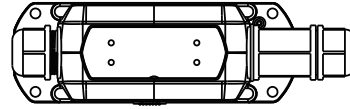

Waterproof plug:
PoE ON/OFF Switch

Connector Assembly

IMPORTANT - please follow the procedures below carefully to ensure the best seal:

1. Fit a BNC plug to the coaxial cable
2. Thread the coaxial cable through the cap(A) & grip(B)
3. Split rubber(C), rubber have two sizes for meet 4.5~6.5mm or 6~8mm coaxial cable.
4. Fit the split rubber(C) over the coaxial cable
5. Thread the coaxial cable through the body(D)
6. Fit the washer(E) to the XE22-110-TX-V2 connector
7. Plug the BNC connector on the coaxial cable into the XE22-110-TX-V2
8. Hold XE22-110-TX-V2 and then screw the body(D) onto the XE22-110-TX-V2 connector tighten firmly
9. Push rubber(C) in the grip(B) and screw the cap tighten firmly. The coaxial cable is sealed when the rubber(C) & grip(B) bulges to the edge of the cap(A). The BNC Male connector needs <38mm form coaxial cable.

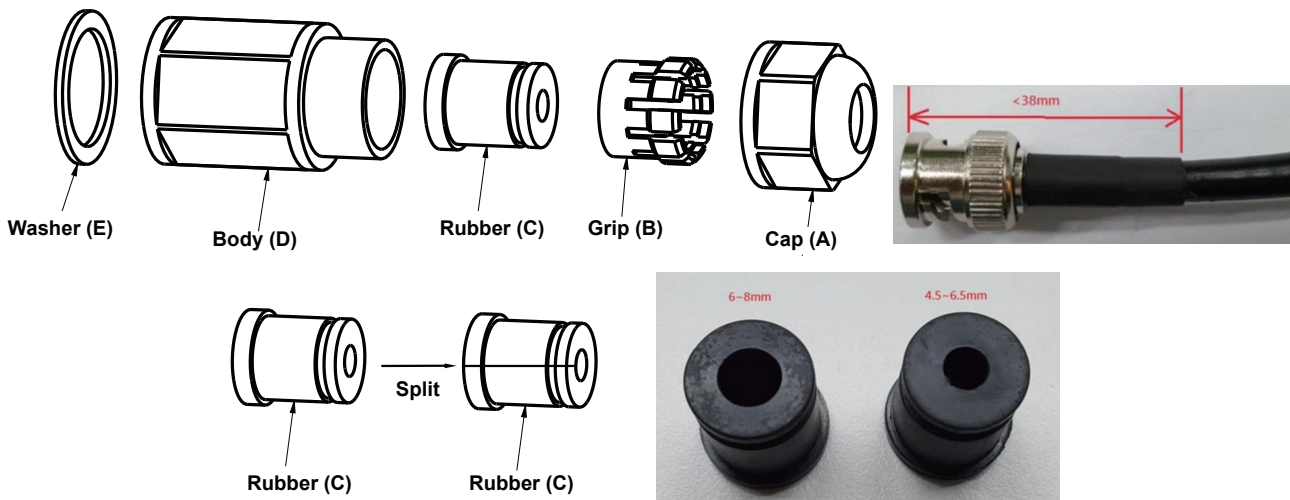

All specifications are subject to change without notice.
Copyright © 2025 AETEK INC. All rights reserved.

AETEK INC.
6F, No.192-1, Lien-Cheng Rd., Chung-Ho, New Taipei City, 235, Taiwan, R.O.C.
| T: +886-2-82452822 | W: www.aetektec.com | E: sales@aetektec.com