



Stainless Steel Camera Housing Series

Installation Guide



Rev. 1.1

UNPACKING:

Unpack carefully. Electronic components can be damaged if improperly handled or dropped. If an item appears damaged in shipment, place it properly in its carton and notify the shipper.

**IMPORTANT!:**

1. Read and follow Instructions: All operating and user instructions should be read and followed before the unit is to be operated.
2. Electrical Connections: Only a qualified electrician is allowed to make electrical connections.

**Specifications**

Model Number	S1000	S2000-I, S2000-IW	S5000	S6000-I, S6000-IW
Power Input	24V AC	24V AC	PoE: 30W, 50-57V DC	PoE: bt 90W, 50-57V DC
Power Output	12VDC, 24VAC	12VDC, 24VAC	PoE, 12VDC	PoE, 24VDC
Power Consumption	Window heater: 5W; Blower: 2W;	Window heater: 5W; Blower: 2W; IR LED: 12W; Wiper: 6W	Window heater: 5W; Blower: 2W;	Window heater: 5W; Blower: 2W; IR LED: 12W; Wiper: 6W
VAIR Illuminator	N/A	850nm 50m@40°, 140m@10°		850nm 50m@40°, 140m@10°
Environmental Operation Temp.	-20°C ~ +65°C (-4°F ~ +149°F)	-20°C ~ +65°C -20°C ~ +50°C (w/IR LED)	-20°C ~ +65°C (-4°F ~ +149°F)	-20°C ~ +65°C -20°C ~ +50°C (w/IR LED)
Window heater ON/OFF	< 30°C (86°F) ON >30°C (86°F) OFF	≤ 20°C (68°F) ON ≥ 30°C (86°F) OFF	≤ 20°C (68°F) ON ≥ 30°C (86°F) OFF	≤ 20°C (68°F) ON ≥ 30°C (86°F) OFF
Blower Control	>30°C (86°F) ON < 30°C (86°F) OFF	≥35°C (95°F) ON ≤ 25°C (77°F) OFF	≥35°C (95°F) ON ≤ 25°C (77°F) OFF	≥35°C (95°F) ON ≤ 25°C (77°F) OFF
Protection Level	IP68, IK10	IP68, IK10 (IP66 w/ wiper)	IP68, IK10	IP68, IK10 (IP66 w/ wiper)
Construction	AISI 316L stainless steel	AISI 316L stainless steel	AISI 316L stainless steel	AISI 316L stainless steel
Dimensions	460 (L) x 172 (W) x 163.5 (H) mm	460 (L) x 172 (W) x 242.5 (H) mm	460 (L) x 172 (W) x 163.5 (H) mm	460 (L) x 172 (W) x 242.5 (H) mm
Net Weight	7.5kg	8kg 8.2kg (wiper model)	7.5kg	8kg 8.2kg (wiper model)
Cable Grants	PG16 x 2	PG16 x 2	PG16 x 2	PG16 x 2

If you plan to install this camera housing into a tropical, sea coastal, or an environment where salt water or corrosive industrial waste water/moist are present, please seal each stainless steel screws and fittings with a silicon grease compounds. This will help prevent electrolysis to occur and extend the life span of the camera and housing.

**IMPORTANT:**

1. Disconnect devices: A readily accessible disconnect device in the building installation wiring should be incorporated.
2. Electrical Connection: Only a qualified electrician is allowed to make electrical connections.

II Mounting Configuration & Dimensions

Swivel Positions and Directions

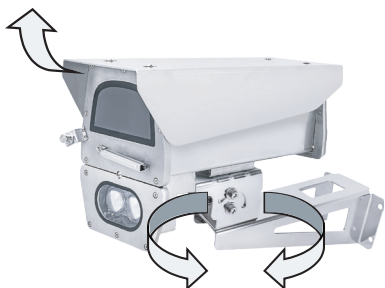

Dimensions

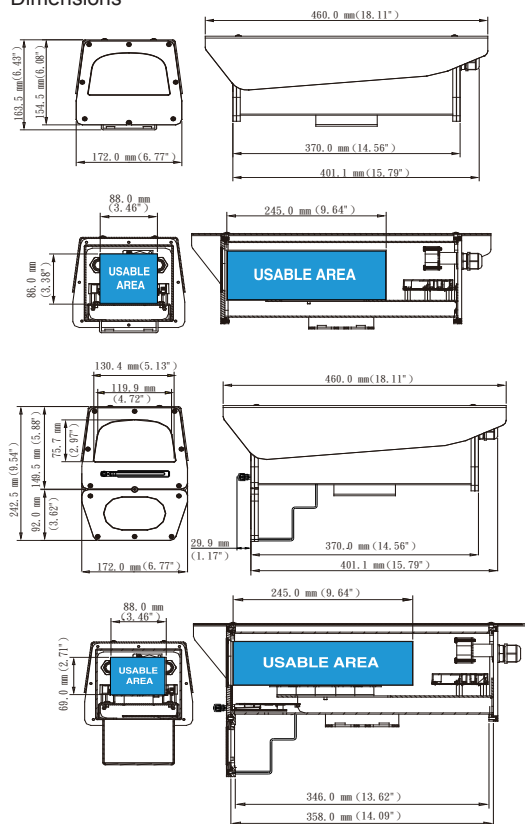

Dimensions with the IR unit and wiper

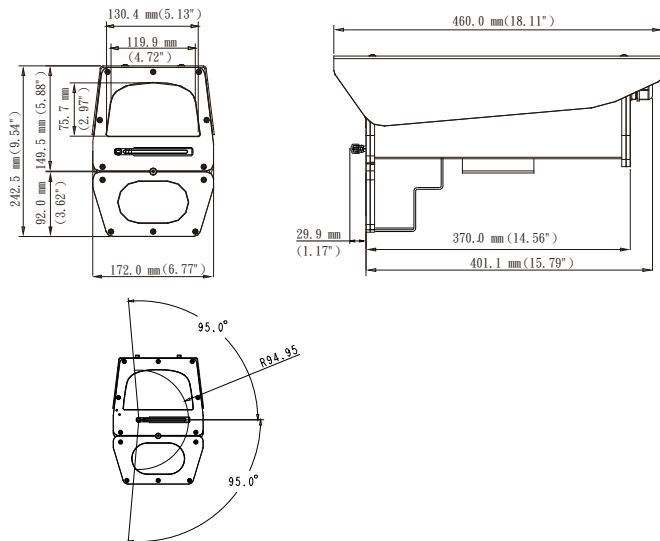

III Component Description

S1000

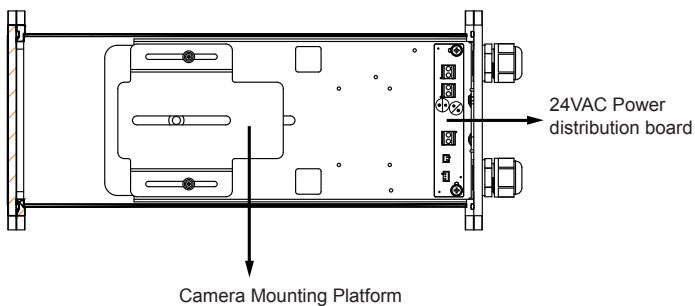

S2000-I, S2000-IW

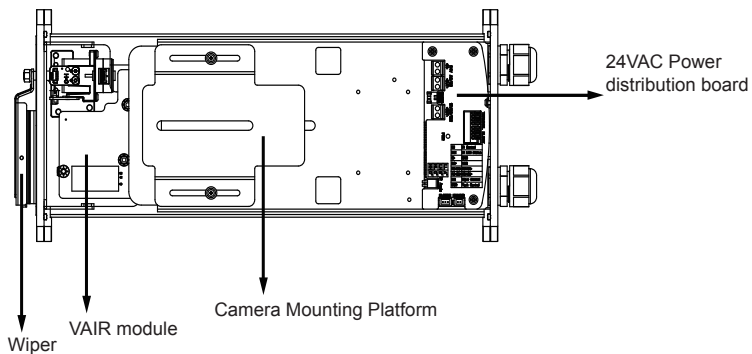

S5000-I, S6000-I, S6000-IW

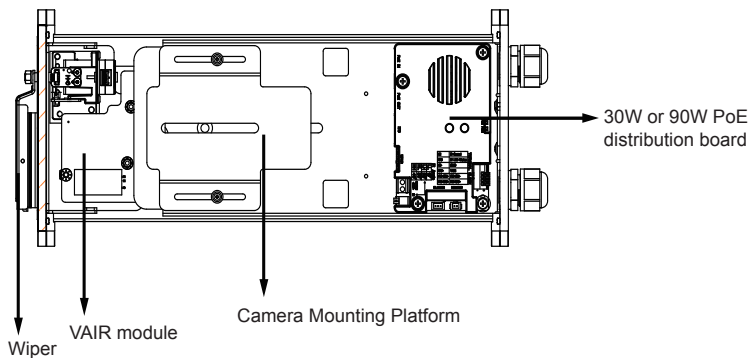

IV Installation Suggestions

⚠ WARNING:

- When install a housing with an IR illuminator:
Please avoid eye exposure or apply appropriate protection, such as wearing a pair of Infrared protection glasses, when working with the product. Always use camera live view to observe IR lighting effects.

V Installation

1. How to open the housing

Unscrew the bolts on the rear flange, using the allen wrench supplied.

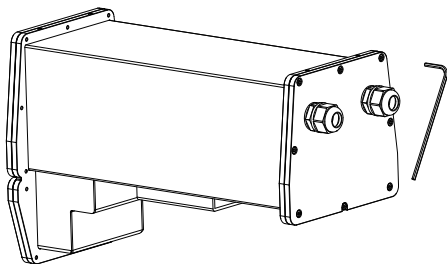

Slide out the rear cover plate of the housing, taking care to leave the sealing washer in its seating. Heater or wiper or VAIR connect need unplugged.

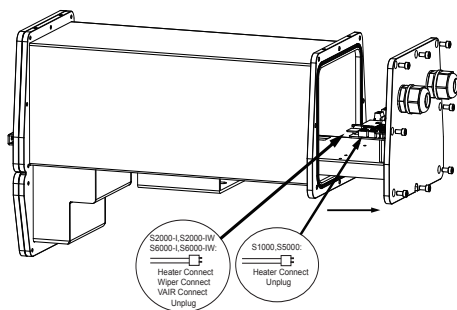

2. Prepare power wires, a ground wire, and a CAT5e Ethernet cable. Pass them through the PG16 waterproof connectors and its waterproof components.

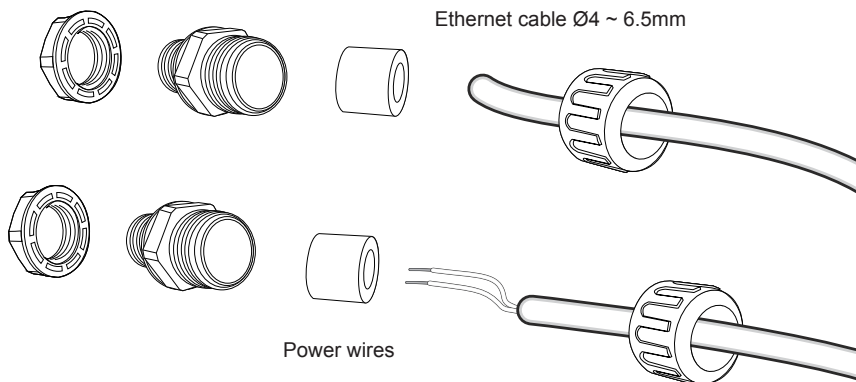

Note that some cables are connected when shipped. You do not need to connect heater, blower, and the front IR power wires.

You may need to remove the RJ45 connector, and use a crimping tool to connect the Ethernet wires to an RJ45 connector inside the enclosure. Use an Ethernet cable of the width of 5 ~ 6.5mm.

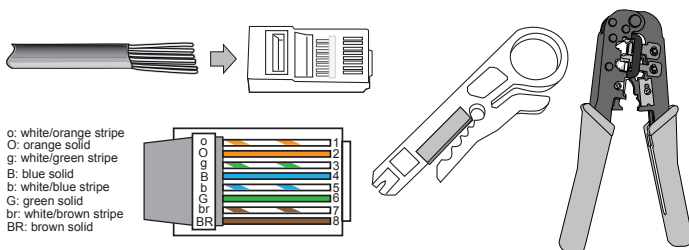

3. When done, tighten up and install the waterproof connectors.

4. Assemble the camera components, e.g., the CS ring and lens module. Secure the mounting plate to the bottom of the camera (the label side) using the included screw.

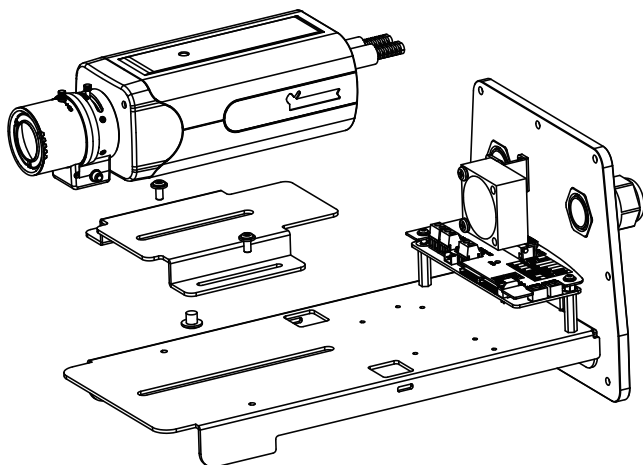

5. Connect 24V power source to the power input terminal. Connect power wires from the DC 12V output to the camera.

Below is the distribution board drawing power from 24V AC.

S1000

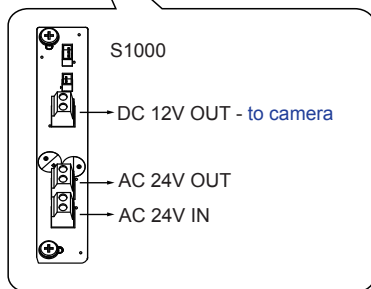
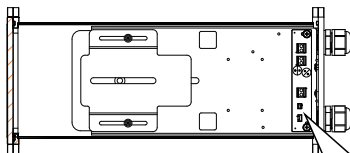

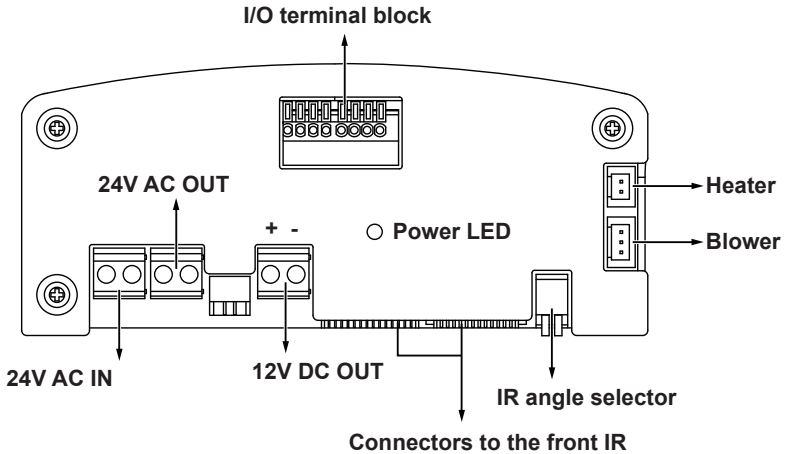

Below is the pinouts for the DI/DO terminal block:

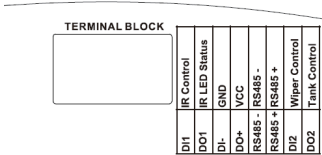

Facing the rear side of the housing, from left to right:

DO2	Connect to tank water pump.
DI2	Wiper control, connects to IP camera's DO for manually triggering washer.
RS485+	RS485+, RS485 can be used to control IR illuminator beam angles, etc.
RS485-	RS485-
DO+	+5V VCC
DI-	GND
DO1	IR LED status
DI1	IR control, synchronizes day/night mode switching for IP camera. It is related to IR cut filter.

S5000

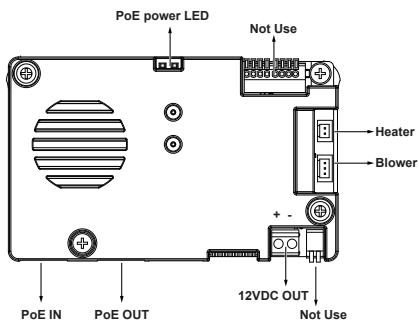

S6000-I, S6000-IW

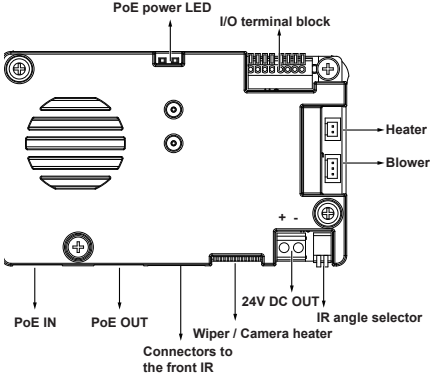

Below is the pinouts for the DI/DO terminal block:

DO2	Connect to tank water pump.
DI2	Wiper control, connects to IP camera's DO for manually triggering washer.
RS485+	RS485+, RS485- can be used to control IR illuminator beam angles, etc.
RS485-	RS485-
DO+	+5V VCC
DI-	GND
DO1	IR LED status
DI1	IR control, synchronizes day/night mode switching for IP camera. It is related to IR cut filter.

Configuring IR illuminator

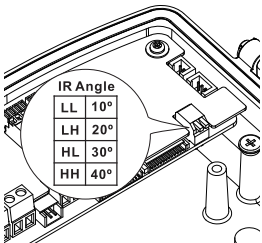

DIP Switch :

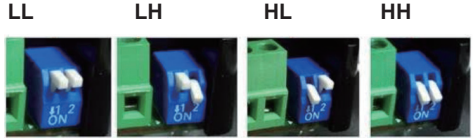

Below are the parameters of the IR illuminator. Use the onboard jumpers to configure the beam angle for different effective illumination range.

VAIR	12W				6W			
	2P				2P			
no. of LEDs								
Beam angle	10°	20°	30°	40°	10°	20°	30°	40°
Distance (meter)	140m	110m	80m	50m	100m	80m	60m	40m

6. Connect the DI/DO signal lines from the distribution board, if applied, to the camera's terminal block.

The day/night mode DI connection enables the synchronization of IR light and the automated day/night switching mechanism on the camera.

A sample use RS485 connection diagram consisting of a housing with IR illuminators and camera is shown below. Please refer to your camera's documentation if your camera comes with different pinouts.

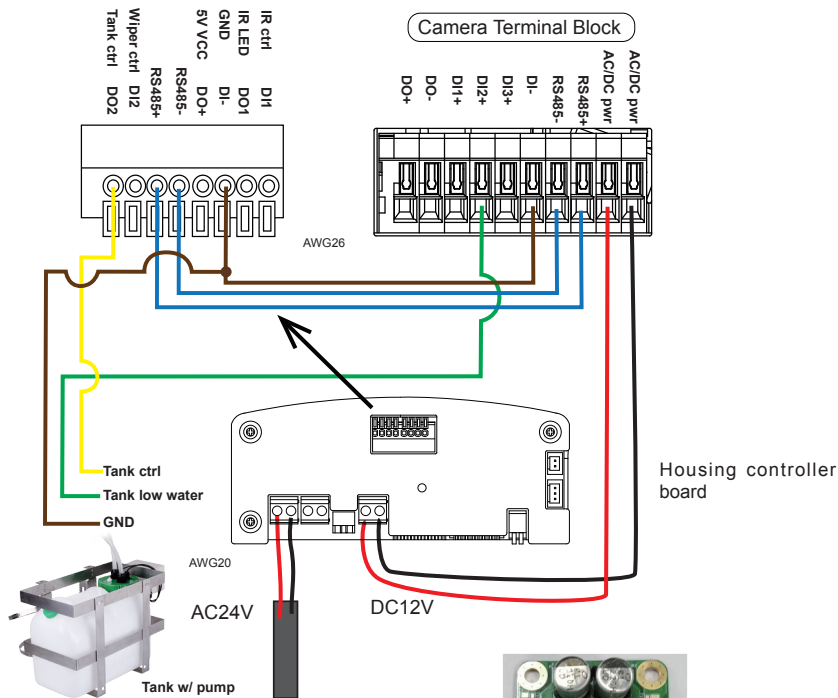

See drawing on the right for the washer kit control board pinouts.

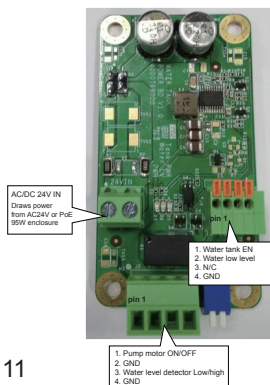

Below is a diagram using wiper control. The wiper can be started by manually triggering the Digital Output from the camera user interface.

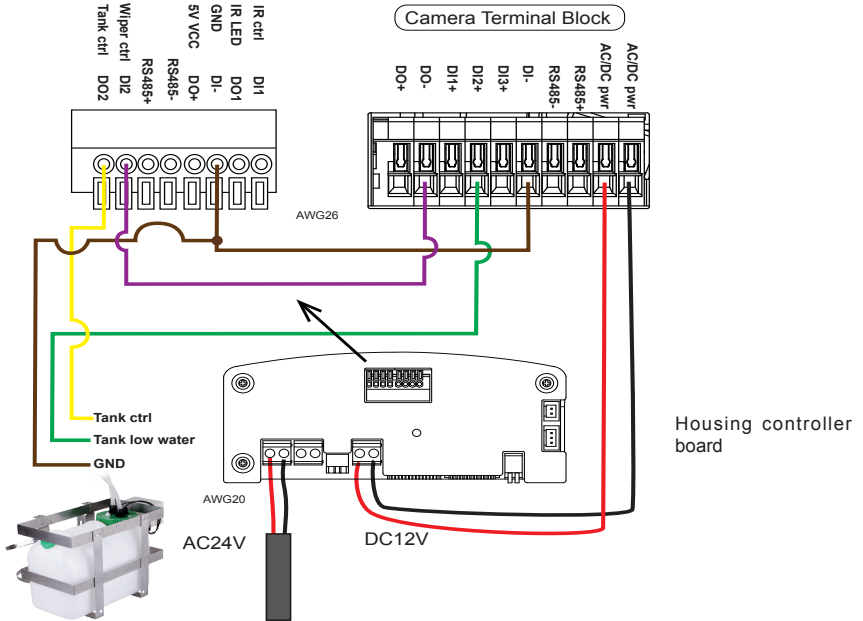

Note the wire gauge requirements for making the power connections.
For 24VAC 24W load,

Wire Gauge	22	20	18	16	14	12
Distance	55	90	150	230	270	600 feet

7. Before closing the housing reinsert the bottom orientating the slide according to the installation required, on the wall bracket or on the Pan & tilt head, for the right camera fitting. Pay attention not to damage the gasket. Make sure that the sealing ring is correctly fitted in its position.

The front end of the slider is about 70mm from the window. Please install the camera in the appropriate position.

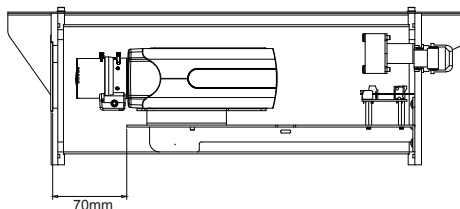

Before closing the housing, be sure to have rightly fitted the internal slide according to the type of installation & plug heater or wiper or VAIR connector to power board.

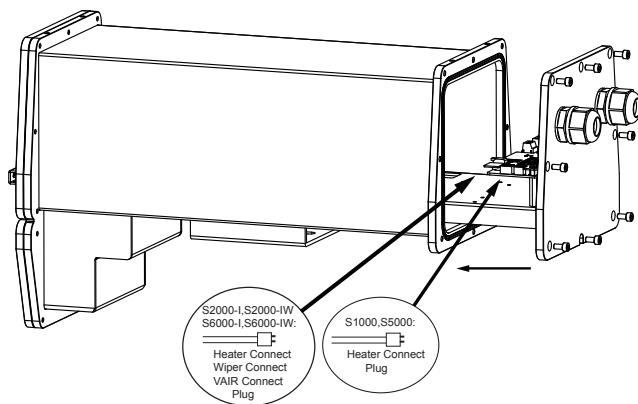

Install wall mount bracket or Cardan joint bracket.

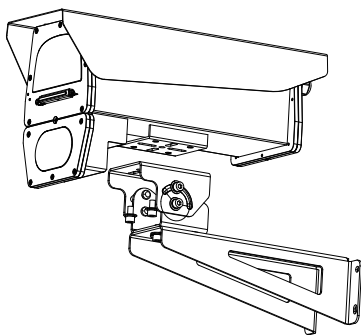

BK-103 :Wall mount bracket
mounting

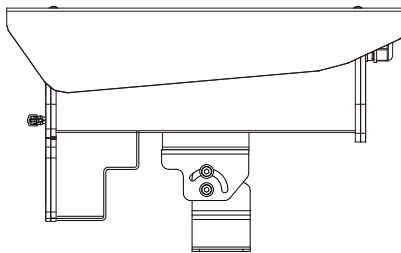

BK-301 :Cardan joint Bracket
mounting

8. Sunshield mounting:

Position the sunshield on the housing and fix it flanges of the housing with the equipped screws.

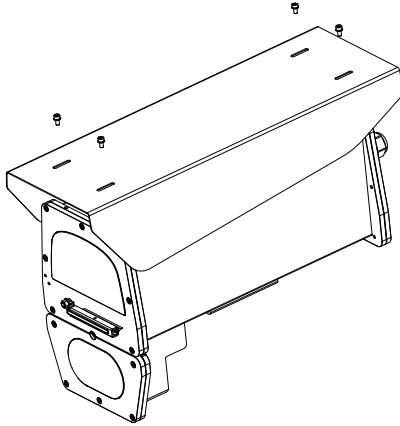

9. The housing can also be installed using the pole-mount or corner-mount.

The mounting hole definition is illustrated below.

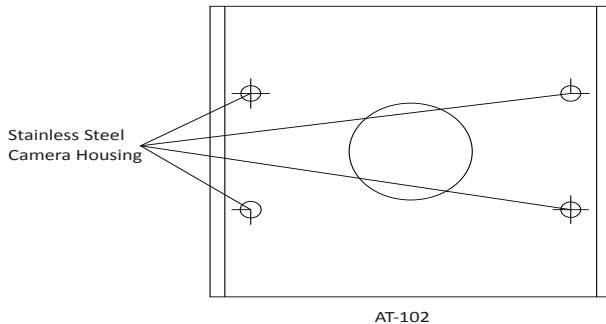

AT-102

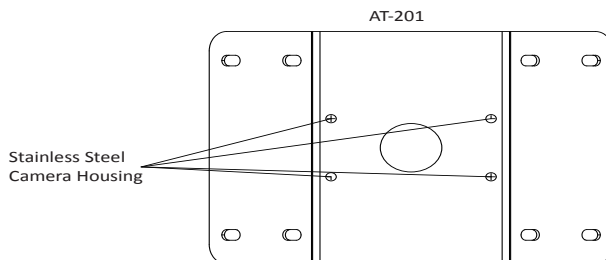

AT-201

VI TP-100 Installation

UNPACKING:

Unpack carefully. Electronic components can be damaged if improperly handled or dropped. If an item appears damaged in shipment, place it properly in its carton and notify the shipper.



IMPORTANT:

1. Read and follow Instructions: All operating and user instructions should be read and followed before the unit is to be operated.
2. Electrical Connections: Only a qualified electrician is allowed to make electrical connections.

VI-1 Introduction

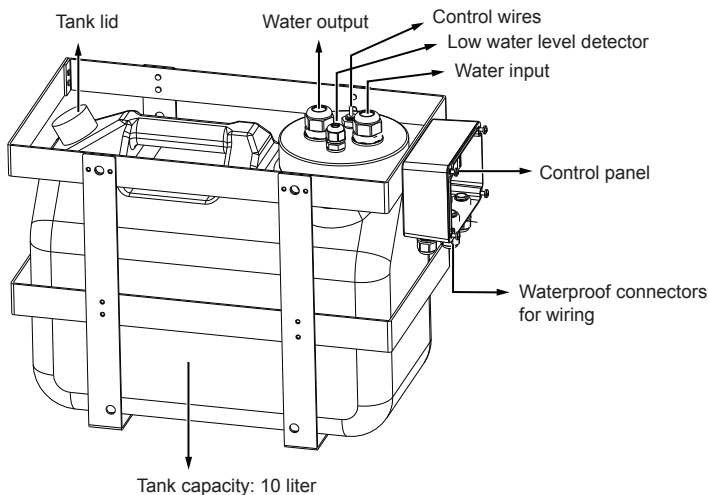

IMPORTANT:

- Disconnect devices: A readily accessible disconnect device in the building installation wiring should be incorporated.
- The total weight of the tank pump is 12kgs. You need to rigid wall surface to support the weight or you can pole-mount the unit.

VI-2 TP-100 Installation

1. Before you install the pump tank, you can temporarily remove the water tank so that you can install the pole-mount brackets.

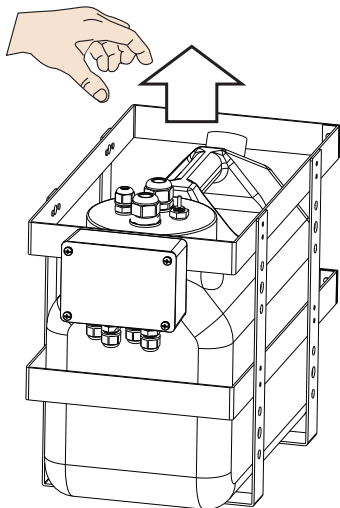

2. Assemble the pump head, water level sensor to the tank lid.

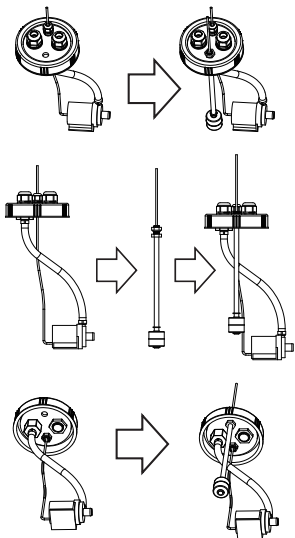

3. Install the controller unit box to the pump bracket. Note that you do not need to install the PCB board.

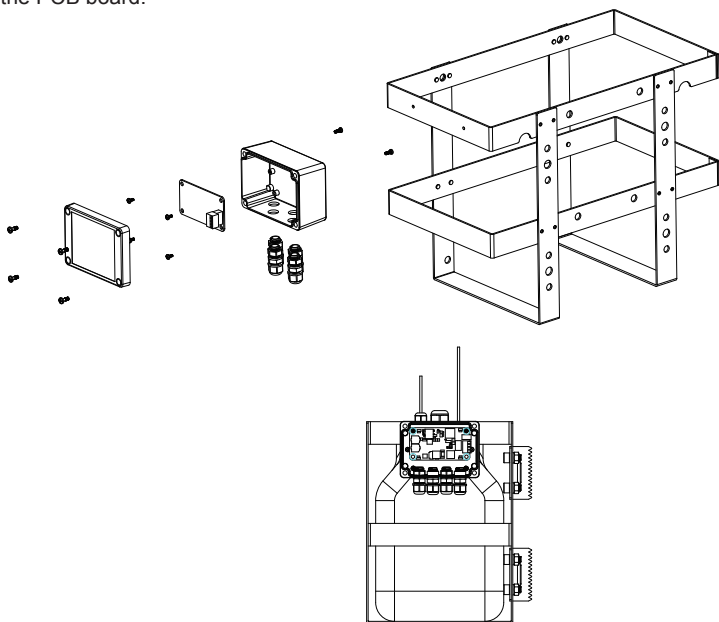

4. You can install the washer unit to a wall or using the pole-mount. If pole-mount is preferred, secure the pole-mount brackets to the metal cage.

Pole-mount bracket

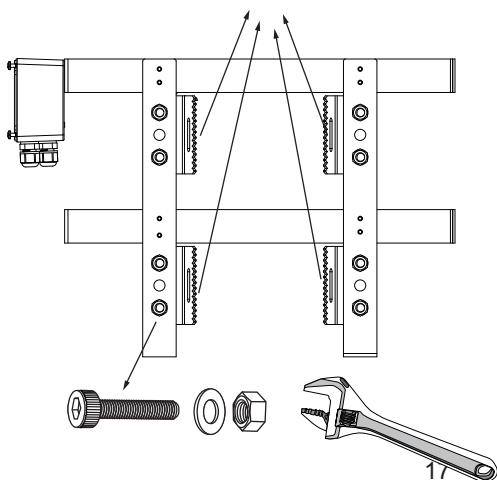

5. Pass the stainless steel straps through the bracket and around the pole. Tighten the straps using a pincer plier and a flat blade screwdriver.

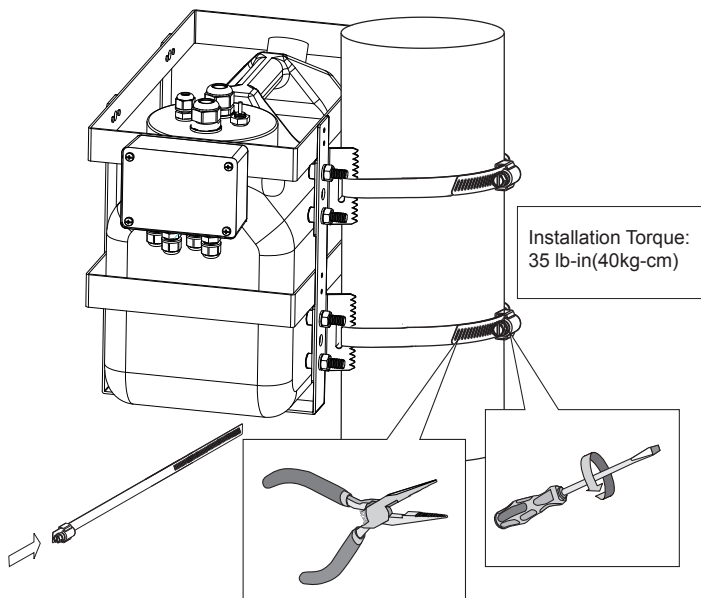

6. Install the washer bracket (along with the washer nozzle) to the side of the P2000-IW using the included screws. Connect the washer silicone pipe to the nozzle. Secure the connection with a cable tie.

The max. pump delivery is 4.5 meters.

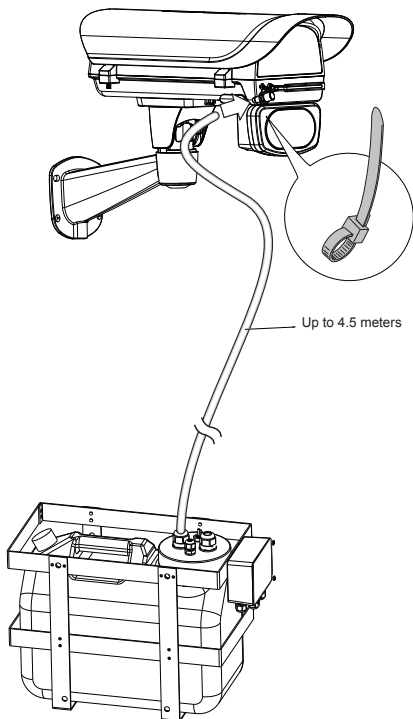

P2000-IW housing with washer kit.

7. Open the waterproof panel box cover. Connect the DI/DO control wires from the Camera Housing to the control panel as illustrated below. Additional length of wires are user-supplied. The pump tank can be powered by 24V AC power source from the PB-024-1AC and PB-024-2AC power box.

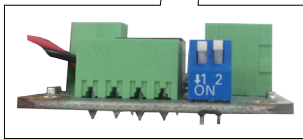
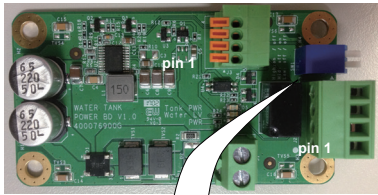

Water Pump Level
 High: ON/OFF
 Mid: OFF/ON
 Low: OFF/OFF

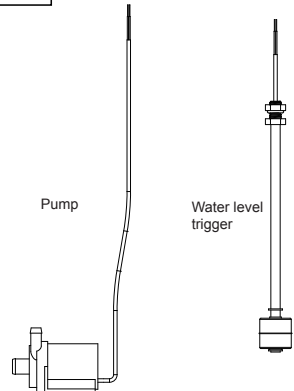

8. Make sure all wirings are waterproof. Lock the cable glands properly. When wiring is done, install the panel cover.

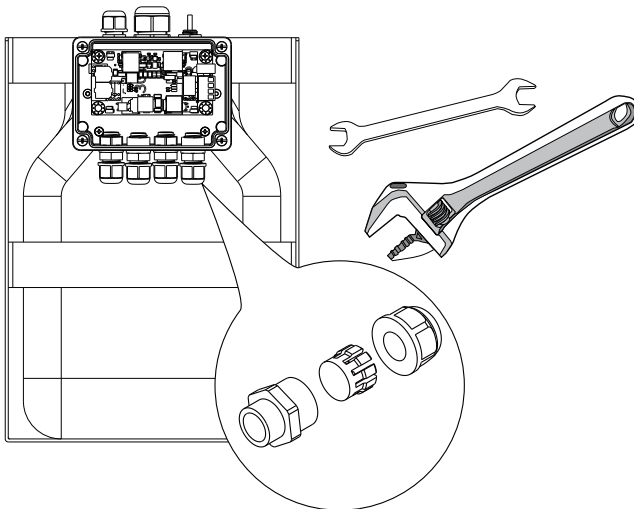

9. Firmware configurable options:

Open a web console with the camera.

Use the Media > Focus function to tune for a best image focus on your target area.

The screenshot shows the 'Focus' configuration page in the camera's web console. The left sidebar lists various system settings, with 'Media' expanded to show 'Image', 'Video', and 'Audio'. The main content area has tabs for 'General settings', 'Image settings', 'Exposure', 'Lens configuration', 'Focus', and 'Privacy mask'. The 'Focus' tab is active, displaying a live video feed of a room with a staircase. Below the feed, there are two main sections: 'Focus window' and 'Focus adjustment'. The 'Focus window' section has a radio button for 'Full view' (which is selected) and an option for 'Custom'. The 'Focus adjustment' section contains a numbered list of instructions: 1. 'Reset' to default back focus position, 2. 'Open iris', 3. Adjust the zoom and roughly make focus using the pullers on the lens, 4. 'Fine-tune focus' and 'Full-range scan focus' buttons, and 5. 'Enable iris'. A 'Focus' slider is visible with navigation arrows and a 'Reset' button.

If preferred, e.g., shooting fast moving vehicles, select the 60fps frame rate.

The screenshot shows the 'Media > Video' configuration page. The left sidebar is the same as in the previous image. The main content area has a 'Media > Video' header and a 'Mode' section with a 'Stream' tab selected. Below the tab, there are three radio button options: 'Dual Stream (Max. 30fps)', 'Video Rotation (Max. 30fps)', and 'Single Stream (Max. 60fps)'. The 'Single Stream (Max. 60fps)' option is selected.

Make sure that external IR is turned on in the night mode, and that the IR cut filter option is synchronized with the digital input you connected.

Media > Image

General settings | Image settings | Exposure | Lens configuration | Focus | Privacy mask

Video settings

- Show timestamp and video title in video and snapshots
- Video title:
- Position of timestamp and video title on image: **Top**
- Timestamp and video title font-size: **Small**
- Color: BW Color
- Power line frequency: 50 Hz 60 Hz
- Video orientation: Flip Mirror Rotate

Day/Night settings

- Switch to B/W in night mode
- Turn on external IR illuminator in night mode
- IR cut filter: **Auto mode**
- Light sensor sensitivity: **Normal**

Day/Night settings

- Switch to B/W in night mode
- Turn on external IR illuminator in night mode
- IR cut filter: **Auto mode**
- Light sensor sensitivity:

Auto mode
Day mode
Night mode
Synchronize with digital input 1
Synchronize with digital input 2
Synchronize with digital input 3
Schedule mode

Save

In the night mode, check if the input signals are correctly detected. You may simulate the night mode by blocking the IR unit's light sensor. Change the triggering parameters when necessary.

Applications > DI and DO

Digital input 1

Normal status: High Low

Current status: **High**

Digital input 2

Normal status: High Low

Current status: **High**

Digital input 3

Normal status: High Low

Current status: **High**

Digital output

Normal status: Open Grounded

Current status: **Open**

Save

VI Appendix: RS485 Commands

For housings that come with IR illuminators, wiper, and washer, commands can be delivered via the RS485 protocol. The RS485 connection uses the Pelco D protocol.

Configuration parameters:

Baud rate	2400
Data bits	8
Parity	None
Stop bit	1

Command format:

Byte1	Byte2	Byte3	Byte4	Byte5	Byte6	Byte7
Sync	Addr	CMND1	CMND2	DATA1	DATA2	CKSM

Addr range: 0x00 ~ 0xFE. CKSM: check sum is the last 8 bits of the sum of Byte2 through Byte6.

Command Group 1:

Command Description	Command (hexadecimal, "ox" is omitted)	Note
ValR Lens Stop	FF 01 00 00 00 00 01	Pelco D - Zoom Stop
VAIR Lens Wide	FF 01 00 40 00 00 41	Pelco D - Zoom Wide
ValR Lens Tele	FF 01 00 20 00 00 21	Pelco D - Zoom Tele
Wiper On	FF 01 00 09 00 01 0B	Pelco D – Aux 1 On
Wiper Off	FF 01 00 0B 00 01 0D	Pelco D – Aux 1 Off
Wiper and Washer On	FF 01 00 09 00 02 0C	Pelco D – Aux 2 On
Wiper and Washer Off	FF 01 00 0B 00 02 0E	Pelco D – Aux 2 Off
IR Led Force On	FF 01 00 09 00 03 0D	Pelco D – Aux 3 On
IR Led Force Off	FF 01 00 0B 00 03 0F	Pelco D – Aux 3 Off

Command Group 2:

Command Name	Command (hexadecimal, ox is omitted)	Note
Addr configuration	FF 01 00 18 01 dd CKSM	dd: 0x00 ~ 0xFE; for example, when addr is 2, the command looks like FF 01 00 18 01 02 1C
IRMode	FF 01 00 18 02 mm CKSM	mm: IR mode mm=0x02: Light Sensor Auto (Default) mm=0x03: DI Trigger mm=0x04: via RS485 Command (When receiving IR Led Force On / IR Led Force Off command, will switch to using the IR Mode -RS485 Command)

		For example, IRmode_Auto FF 01 00 18 02 02 1D IRmode_DI FF 01 00 18 02 03 1E IRmode_CMD FF 01 00 18 02 04 1F
LightSensorGate	FF 01 00 18 03 LL CKSM	When the IR Mode Light Sensor Auto, the Lux value to turn IR LED can be configured. LL: Lux, changes is made by every10Lux For example: LightSensorGate = 100 FF 01 00 18 03 0A 26 LightSensorGate = 200 FF 01 00 18 03 14 30

The parameters of IR illuminator can be controlled via the RS485 connection. You can enable the connection in **Configuration > PTZ > Mechanical** window. Select the defaults for the IR illuminator: Pelco D, baud rate - 2400, Data bits - 8, Stop bit - 1, Parity - none.

The screenshot shows the 'PTZ > PTZ settings' window. The 'Mechanical' tab is selected. Under 'RS485 settings', the 'PTZ camera' option is chosen. The 'Camera ID' is set to '1'. The 'PTZ driver' is set to 'None'. The 'Port settings' section includes: Baud rate (38400), Data bits (8), Stop bits (1), and Parity bits (none). A callout box lists the 'Defaults for IR: Pelco D, 2400, 8, 1, none'. At the bottom, there are buttons for 'Preset position', 'Custom command', and 'Save'.

You can create custom command buttons by entering the Button name and the command itself:

>Custom command

Custom command

Leaving the "Button name" field empty means the command button will not be displayed in the homepage.

	Button name	Command
Command 1:	TH10%	FF012101B00003D6
Command 2:	TH20%	FF012101B00005D8
Command 3:	TH50%	FF012101B00007DA
Command 4:	DIMMING100%	FF012101BF0009EB
Command 5:	DIMMING60%	FF012101B00007DA

Save Close

ValR: The VAIR control include those on the IR Led and ValR Lens.

There are 3 IR mode commands

- IRMode = Light Sensor Auto (Default)
 - sensor lux reading < LightSensorGate - LED On
 - sensor lux reading >= (LightSensorGate + 10 Lux) - LED Off
- IRMode = DI_1 Trigger (IR triggered on by DI)
 - DI_1 shorted DI -(Low) - LED On
 - DI_1 open (High) - LED Off
- IRMode = controlled by RS485 Command (Pelco D – Aux 3 On/Off)
 - IR Led Force On - LED On
 - IR Led Force Off - LED Off
- DO_1 as IR Status Feedback
 - LED On, DO_1 is grounded via MOSFET (DI- connected)
 - LED Off, DO_1 no input

ValR Lens Zoom control

Dip Switch

4 configurations using the Dip Switch on the distribution board.

When Lens stops, its last position will be memoried, and when powered on again, lens will move to the previous position. When powered on for the first time, Lens will follow the DIP switch configuration.

Wiper & Wahser control)

DI_2 Trigger:

When DI_2 connected to DI- (Low), wiper and washer operate for 3 times and then stop.

Using RS485 Command –Wiper Only (Pelco D – Aux 1 On/Off)

Wiper On, wiper takes action

Wiper Off, wiper starts one operation and then stops.

RS485 Command –Wiper & Washer (Pelco D – Aux2 On/Off)

Wiper and Washer On, pumps and spray water with wiper action.

Wiper and Washer Off, spraying and wiping starts one operation and then stops.

DO2 used for spraying control

DO_2 connected to DI- via MOSFET - starts spraying.

Spraying stops, and the LED turns Off when DO_2 is not triggered.

This page is intentionally left blank.