

Model	Description
D51-044-30-V2	4xGbE 30W PoE+2xGbE SFP+ 2xGbE RJ45 48-56 VDC Input
D51-044-90	4xGbE 90W PoH PoE+2xGbE SFP+ 2xGbE RJ45 48-56 VDC Input
D51-044-91	4xGbE 90W bt PoE+2xGbE SFP+ 2xGbE RJ45 48-56 VDC Input
D51-084-30-V2	8xGbE 30W PoE+4xGbE SFP 48-56 VDC Input

Model	Description
D51-044-30-DC-V2	4xGbE 30W PoE+2xGbE SFP+ 2xGbE RJ45 12-56 VDC Input
D51-044-90-DC	4xGbE 90W PoH PoE+2xGbE SFP+ 2xGbE RJ45 12-56 VDC Input
D51-044-91-DC	4xGbE 90W bt PoE+2xGbE SFP+ 2xGbE RJ45 12-56 VDC Input
D51-084-30-DC-V2	8xGbE 30W PoE+4xGbE SFP 12-56 VDC Input

### INTRODUCTION

The D51/D51-DC series is a 4/8 port 10/100/1000BaseT at PoE/ bt PoE switch capable of feeding 15.4/30W or 15.4/30//60/90W (54Vmax. per port) power to Power over Ethernet (PoE) devices. It comes with another 2x GbE TP port + 2xGbE SFP port or 4xGbE SFP port.

### PACKAGE CONTENTS

* 1x PoE switch	* 1x Quick Installation Guide	* 1x 4-pin terminal block
* 1x DB9F-RJ45 console cable	* 1x DIN rail bracket	* 2x 2-pin terminal block

### ⚠ IMPORTANT:

1. Install the converter in a ventilated and dry place that is free of electromagnetic source, vibration, moisture, and dust.
2. Make sure the ventilation openings on the converter are not blocked.
3. Use fiber optic cables and transceiver compliant with the following: Multi-mode: 50/125um, 62.5/125um, 850nm; Single-mode: 9/125um ,1310nm.
4. DC input (48~57VDC or 12~56VDC). Follow the printed polarity for V+, V-, and Ground.
5. Digital output (relay): ON/OFF, support 24VDC/1A. Digital input: level 0(Low), level 1(High).

### CONNECTION

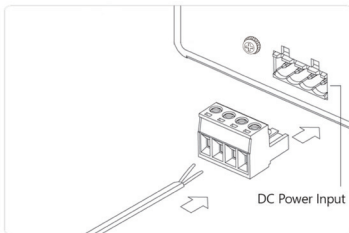

1. Pull out the 4-pin terminal block.
2. Connect power wires to V+, and V-.
3. Connect SFP transceivers to the fiber port.
4. install the 4-pin terminal block.

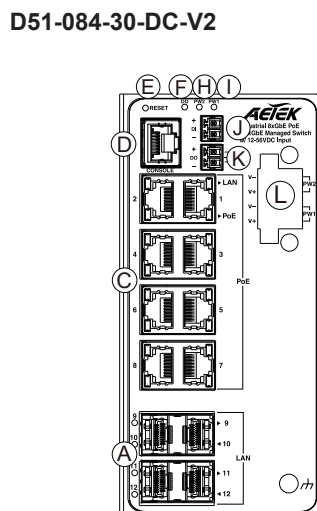
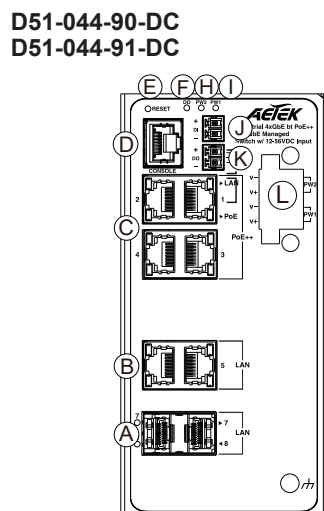
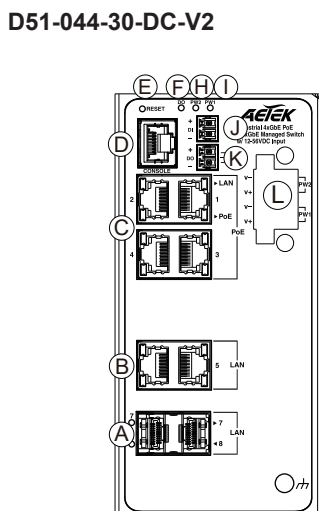
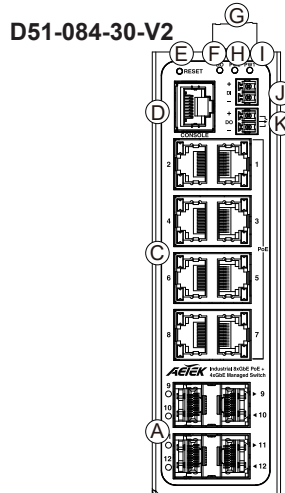
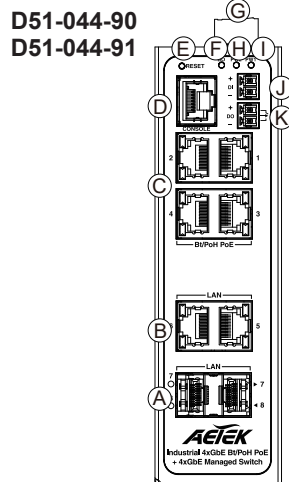
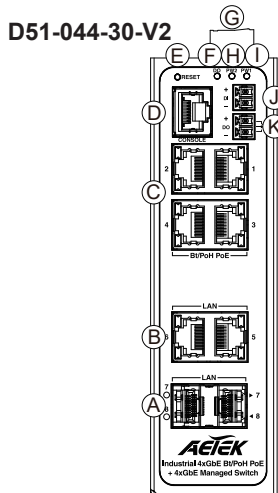
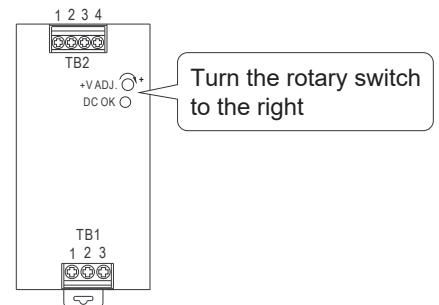

- (A) 100/1000 SFP ports
- (B) 10/100/1000 RJ45 ports
- (C) 10/100/1000 PoE RJ45 ports
- (D) Console port
- (E) Reset button
- (F) DO LED
- (G) 48~56VDC Input
- (H) Power2 LED
- (I) Power1 LED
- (J) Digital input
- (K) Digital output
- (L) 12~56VDC Input

## DEFAULTS

IP Address	192.168.1.1
Subnet Mask	255.255.255.0
User Name	admin
Password	admin

## Power LEDs

LED	Color	State	Description
Power1	Green	On	Powered on correctly.
		Off	Not receiving power from power1.
Power2	Green	On	Powered on correctly.
		Off	Not receiving power from power1.

## DO LED

LED	Color	State	Description
System	Yellow	On	DO ON
		Off	DO OFF

## Console Port Defaults

Baud rate	115200
Stop bits	1
Data bits	8
Parity	N
Flow control	none

## Port Status LEDs

LED	Color	State	Description
RJ45 Ports Up (PoE)	Amber	On	The port is enabled and supplying power to connected device.
		Off	The port has no active connection, or it is not connected to a PoE PD device. Otherwise, the port may have been disabled through the switch user interface.
RJ45 Ports Down (LAN)	Green	On	The port is enabled and established a link to connected device.
		Blinking	The port is transmitting/receiving packets.
SFP Ports	Green	On	The port is enabled and supplying power to connected device.
		Blinking	The port is transmitting/receiving packets.
		Off	The port has no active network connection, or it has no established link to connected device. Otherwise, the port may have been disabled through the switch user interface.

## Reset button

Task	Method	SYS LED Behavior	Port Status LED Behavior
Reset	Press 2 ~ 7 seconds	Blinking Green	All LEDs Off.
Restore Defaults	Press 7 ~ 12 seconds	Blinking Green	All LEDs On.

## DI/DO Connection Diagram

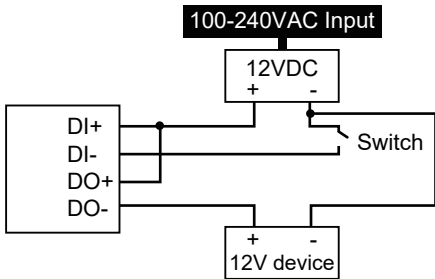

## DI/DO Connection Diagram w/ AC or DC Relay

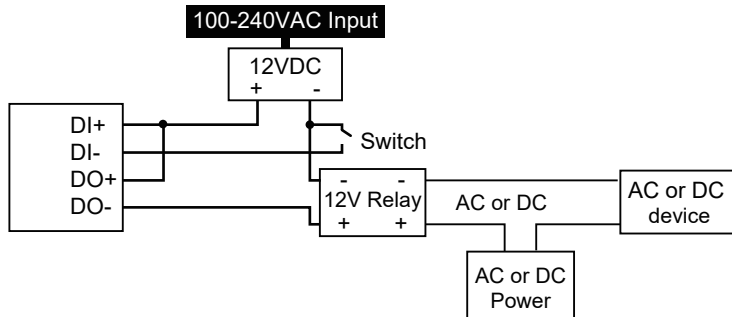

## DIN Rail Installation

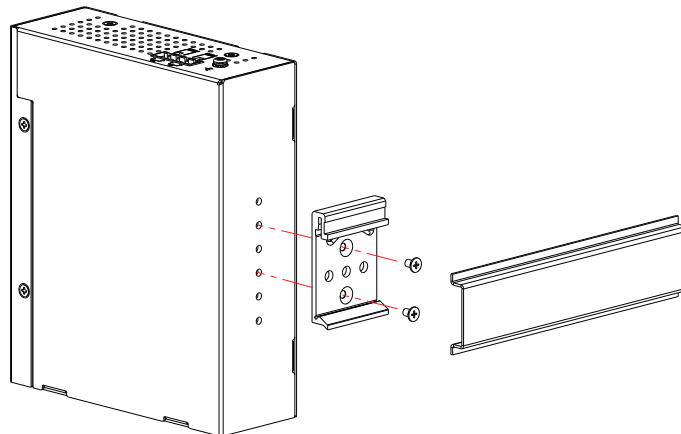

All specifications are subject to change without notice.  
Copyright © 2024 AETEK INC. All rights reserved.