



P2915 Kit A/B P2925 Kit A/B ANPR Camera Housing Solution

Installation Guide



Rev. 1.0

CAUTION:

TO REDUCE RISK OF FIRE OR ELECTRIC SHOCK, DO NOT REMOVE COVER.
NO USER SERVICEABLE PARTS INSIDE.
REFER SERVICING TO QUALIFIED SERVICE PERSONNEL.

UNPACKING:

Unpack carefully. Electronic components can be damaged if improperly handled or dropped. If an item appears damaged in shipment, place it properly in its carton and notify the shipper.



IMPORTANT!:

1. Read and follow Instructions: All operating and user instructions should be read and followed before the unit is to be operated.
2. Electrical Connections: Only a qualified electrician is allowed to make electrical connections.

	P2915 Kit A/B	P2925 Kit A/B
IR Illuminator Specifications		
IR lights catch vehicle speed	MAX: 150km/h (93MPH)	MAX: 250km/h (156MPH) *fit Global shutter camera like equipped with Sony IMX264 or IMX265 sensor
IR lights cover FOV	2 Lanes	2 Lanes
VAIR light beam angle	10° ~ 40° Kit A 20° ~ 40° Kit B	10° ~ 40° Kit A 20° ~ 40° Kit B
Adjustable angle way	• Manual DIP • Remote control by Pelco D via RS485	• Manual DIP • Remote control by Pelco D via RS485
IR light sensor sensitivity	• Pelco D via RS485 • Remote controller	• Pelco D via RS485 • Remote controller
Power consumption	80W	24W (288W pulse mode)
Power input	AC24V or DC24V	DC24V
Camera Housing Specifications		
Window heater	V	V
Blower	V	V
Weather rating	IP68	IP68
Power input	AC24V	AC24V
Power output	DC24V, DC12V	DC24V, DC12V
Power consumption	100W	44W (288W Pulse Mode)
Vandal proof	IK10	IK10
Operating temperature	-20°C ~ +50°C (-4°F~122°F)	-20°C ~ +50°C (-4°F~122°F)
Optional add-on heater Operating temperature	-50°C ~ +50°C (-58°F~122°F) P2915-A is available	-50°C ~ +50°C (-58°F~122°F) P2925-A is available

II Mounting Configuration & Dimensions

Swivel Positions and Directions

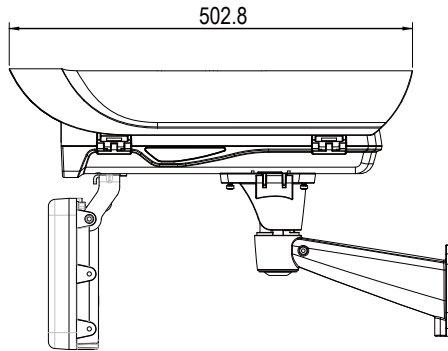
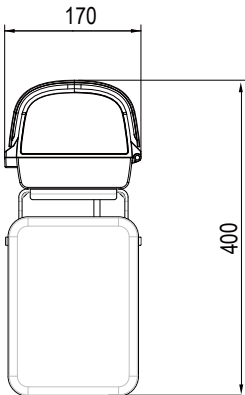
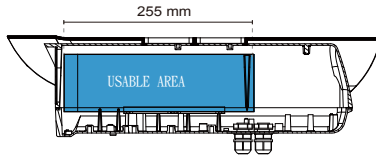
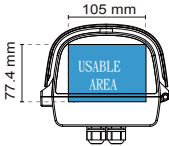
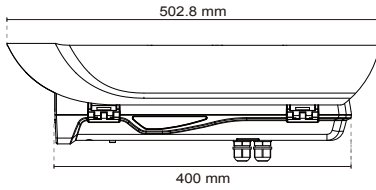
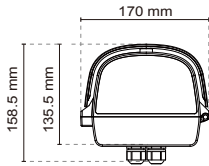

III Component Description

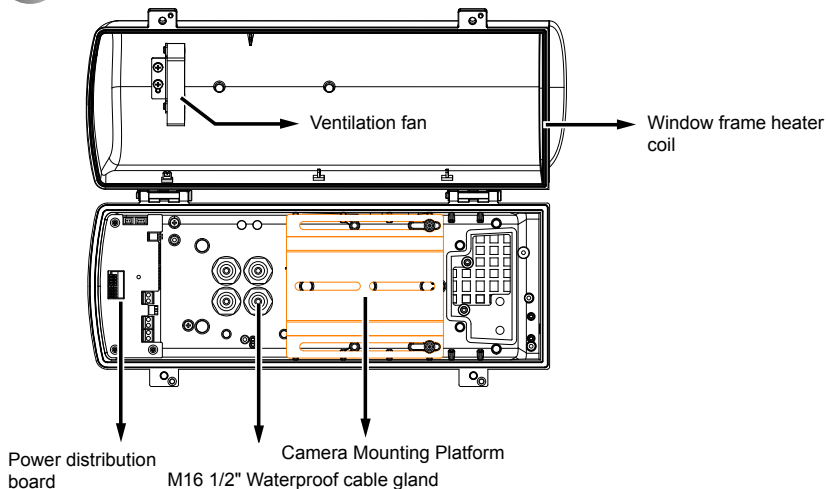

IV Installation Suggestions

If you plan to install this camera enclosure into a tropical, sea coastal, or an environment where salt water or corrosive industrial waste water/moist are present, please seal each stainless steel screws and fittings with a silicon grease compounds. This will help prevent electrolysis to occur and extend the life span of the camera and housing.



IMPORTANT:

1. Disconnect devices: A readily accessible disconnect device in the building installation wiring should be incorporated.
2. Electrical Connection: Only a qualified electrician is allowed to make electrical connections.



WARNING:

- Please avoid eye exposure or apply appropriate protection, such as wearing a pair of Infrared protection glasses, when working with the product. Always use camera live view to observe IR lighting effects.

V Installation

1. Install the wall-mount bracket to a preferred location at your installation site. Drill mounting holes and a cable routing hole (if preferred) on a wall. Install the bracket. Prepare and route the wiring, Ethernet and 24V power source.

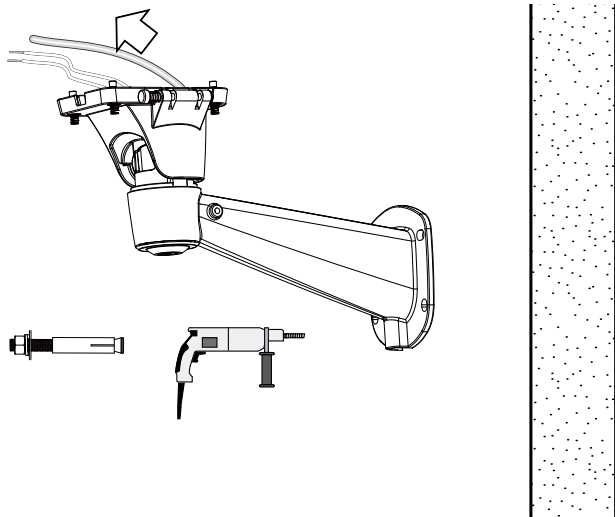

2. Install the IR illuminator to the bottom of the housing. Attach the included grip stricker to the U bracket.

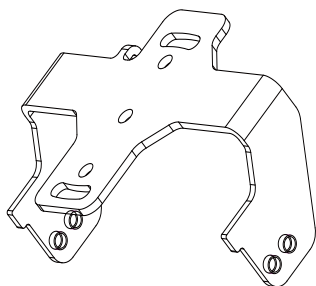

3. Secure the U bracket to the IR illuminator using the included hex screws.

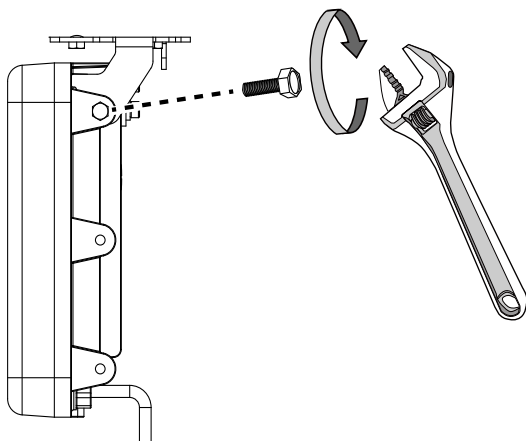

4. Flip the housing over and place it on a clean, stable surface. Secure the IR illuminator to the bottom of the housing using the included wrench and a hex socket screw.

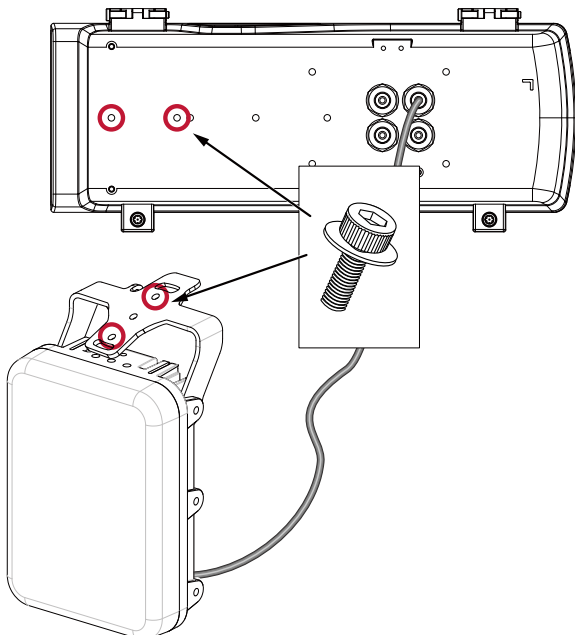

5. You can turn the IR illuminator so that its flat side is parallel with the housing, and that you can turn the assembly over and work on the inside of the housing. Put a foam pad below before you work on the wiring to avoid scratching the surface.



6. Prepare power wires, a ground wire, and a CAT5e Ethernet cable. Pass them through the M16 waterproof connectors under the housing.

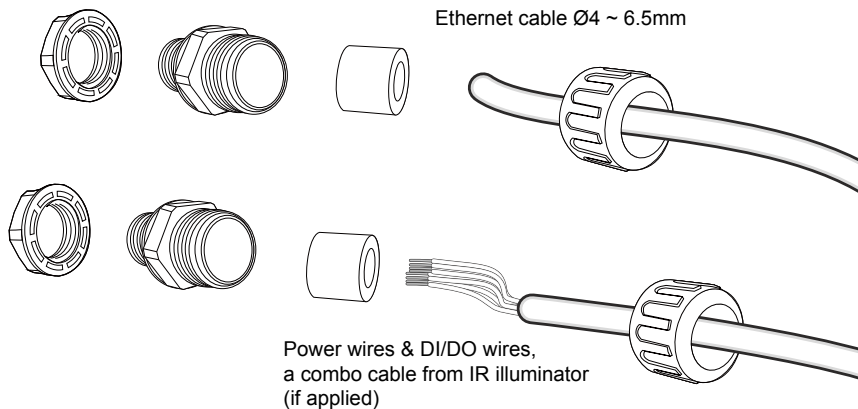

You may need to remove the RJ45 connector, and use a crimping tool to connect the Ethernet wires to an RJ45 connector inside the enclosure. Use an Ethernet cable of the width of 4 ~ 6.5mm.

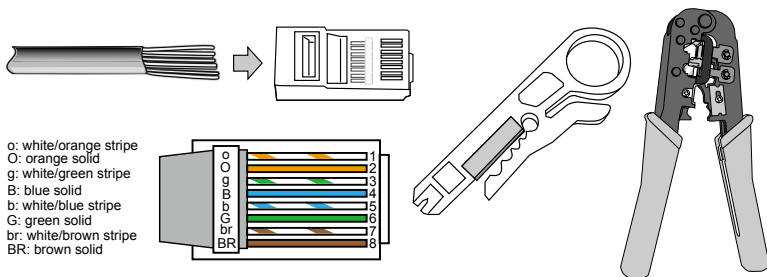

7. When done, tighten up and install the waterproof connectors.

8. Assemble the camera components, e.g., the CS ring and lens module. Secure the mounting plate to the bottom of the camera (the label side) using the included screw.

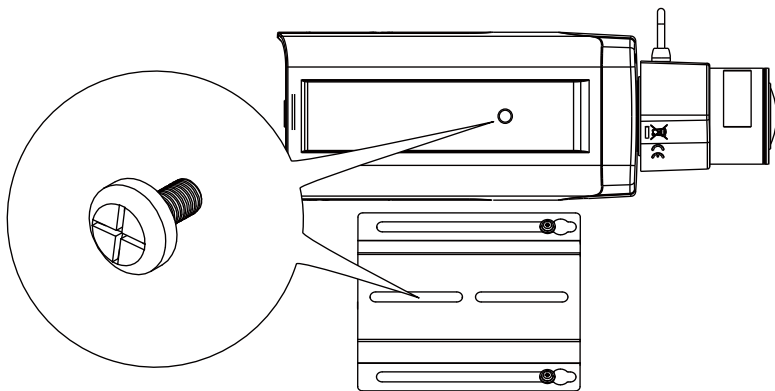

There is a plastic mount pad in the package. You do not need the mounting pad using the AETEK camera.

9. Adjust the camera's position so that the lens module can flush align with the tempered glass. Secure the camera using the screws and washers to the bottom of the housing.

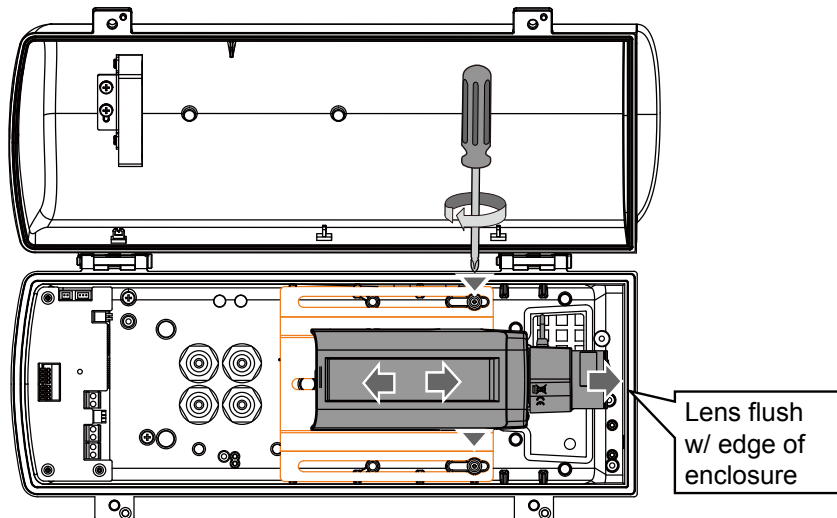

10. Connect 24V power source to the power input terminal. Connect power wires from the DC 12V output to the camera. Connect the 24V power output to drive the external IRs.

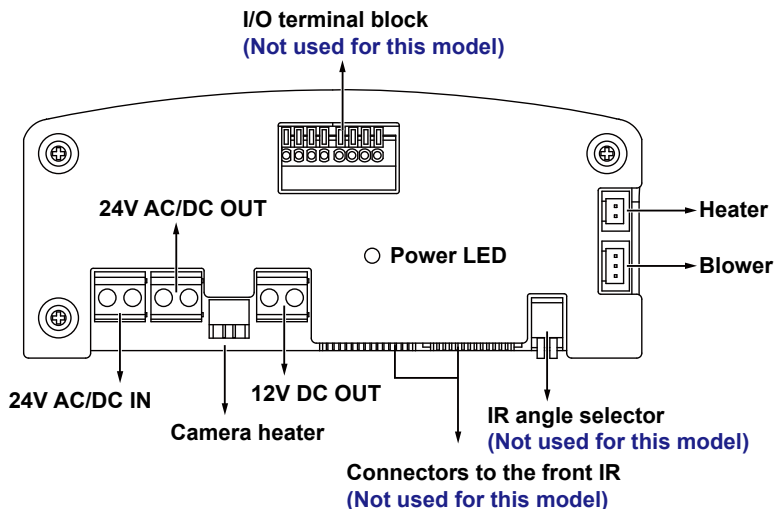

IMPORTANT:

You should prepare a power adaptor of the sufficient capacity for supplying 24V input. Below are the requirements:

	Total consumption	Power adaptor
P2915 Kit A/B	100W	7A
P2925 Kit A/B	44W	5A

- 11.** Connect the Ethernet cable to the camera's RJ45 socket.
- 12.** Also pass the combo cable of the IR illuminator through a waterproof connector.
- 13.** Connect the day/night signal lines from the IR unit to the DI/DO connectors on the camera's terminal block. The P2915 Kit A/B & P2925 Kit A/B is shown here.

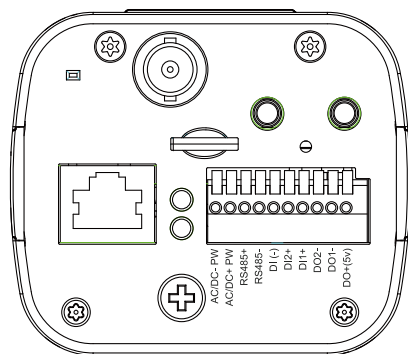

The day/night mode DI connection enables the synchronization of IR light and the automated day/night switching mechanism on the camera.

Cable Pinouts (IR Illuminator)

Name	Color	Gauge	Description
V+	Red	(20AWG)	Power input
V-	Black	(20AWG)	12~24V DC \pm 10% 24V AC \pm 10% (50~60Hz), (14.5VDC current controlled)
DI+	Green	(26AWG)	LED ON/OFF control * Dry contact Logic level 1(Open) = LED off Logic level 0(Close to GND) = LED on * Wet contact Logic level 1: 4V~40 V = LED off Logic level 0: 0.8V MAX = LED on
DI-	Yellow	(26AWG)	Ground
DO+	Purple	(26AWG)	Light sensor status output 1. Open = Day 2. Short = Night (20 lux for IR ON); day/night switch will have a 30 sec. delay.
DO-	Blue	(26AWG)	Ground
RS485+	Orange	(26AWG)	RS485 interface control
RS485-	Brown	(26AWG)	

A sample connection diagram consisting of CaMate's IR illuminators and the camera is shown below. Please refer to your camera's documentation if your camera comes with different pinouts.

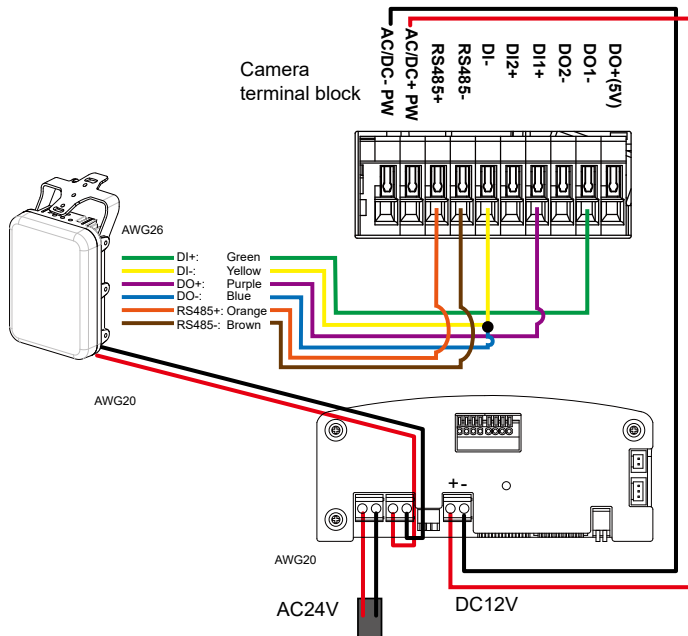

14. You can connect the ground wires together and connect them to the DI- ground pin on the terminal. Use a small flat blade screwdriver to press the lever on the terminal block.

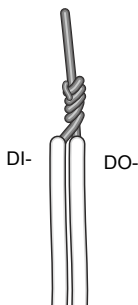

The default for the DI status is listed below:

DI	Normal: High Current Status: > High - Day mode. > Low - Night mode (IR is on)

- 15.** Secure the intersection bracket to the bottom of the housing by driving two screws.

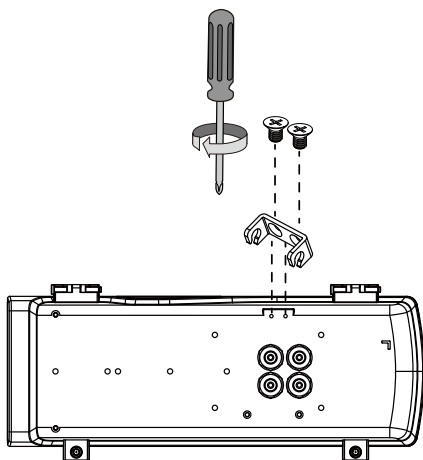

- 16.** Install the housing to the wall-mount bracket by aiming and pressing the spring mortise, and hook the bracket onto the groove in the spring mortise.

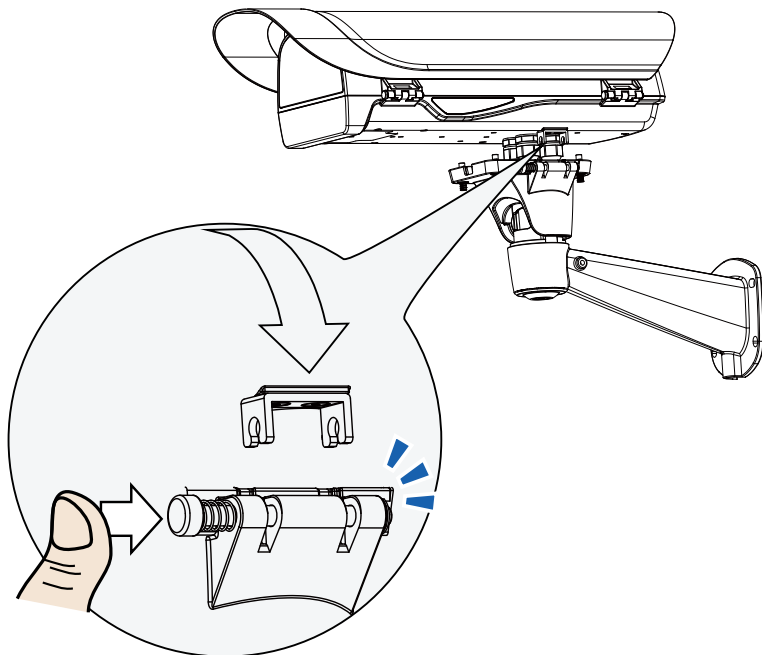



When mounting the housing, please carefully place the cable within the cutout on the bracket. There is a cutout for routing the cable.

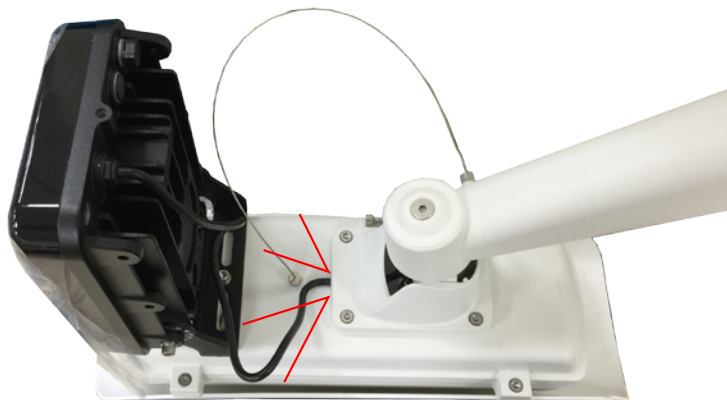

17. Secure the housing to the bracket by fastening 4 T30 screws.

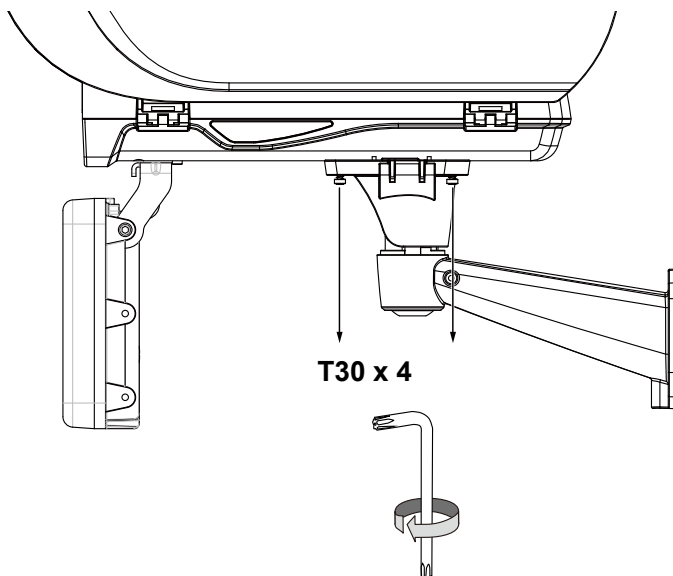

18. Adjust zoom and focus and open a web console with the camera to tune for the best image. When zoom and focus is done, Close the top cover and fasten the hex screws from below.

This page is intentionally left blank.