

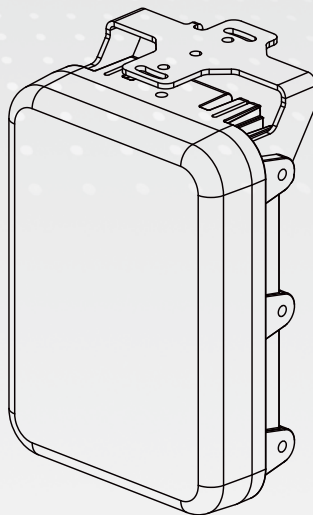

VR-486 / VW-486 / VR-806 Series

# Vari-Angle Illuminator

Installation Guide



Rev. 1.0

## Revision History:

\* Rev. 1.1: Initial Release

## Package Contents

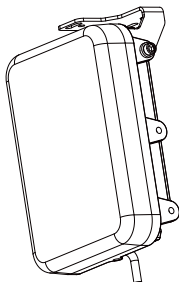
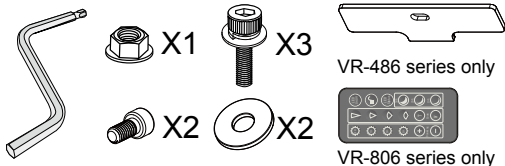

The 1/4" screws and washers are used to secure the illuminator to an external camera housing.



### NOTE:

- The wall-mount , laser alignment kit , remote controller , and other accessory are separately purchased.
- The screws and anchors for securing the illuminator to wall are user-supplied. Apply M6 anchors or screws.



### WARNING:

- Please avoid eye exposure or apply appropriate protection, such as wearing a pair of Infrared protection glasses, when working with the product. Always use camera live view to observe IR lighting effects.
- The luminaire should be positioned so that prolonged staring into the luminaire at a distance closer than 2.5 m is not expected.
- The external flexible cable or cord of this luminaire cannot be replaced; if the cord is damaged, the luminaire shall be destroyed.
- The light source of this luminaire is not replaceable; when the light source reaches its end of life the whole luminaire shall be replaced.
- Please make sure Reinforce/Double insulation shall be maintained between LV supply and control circuits after installation.
- This flood light shall be used with a IEC/EN 61347-2-13 approved LED driver with SELV output equal to rated voltage of the luminaire, and output power of LED drivers shall be at least equal to rated power of the luminaire.
- Terminal block is not included. Installation may require advice from a qualified personnel.

### RISK GROUP 3

WARNING IR emitted from this product.  
Do not look at operating lamp.

IR illuminators RISK GRORP 3 / WARNING IR emitted from this product. / Avoid eye exposure. Use appropriate shielding or eye protection. Do not look at operating lamp.



Class III luminaires



Do not stare at the operating light source.



This marking indicates that this product should not be disposed with other household wastes throughout the EU. To prevent possible harm to the environment or human health from uncontrolled waste disposal, recycle it responsibly to promote the sustainable reuse of material resources. To return your used device, please use the return and collection systems or contact the retailer where the product was purchased. They can take this product for environmental safe recycling.



### IMPORTANT:

- Do not install the product with unstable brackets, or installed on fragile mount surfaces.
- This product shall be used in compliance with local laws and regulation.
- Please avoid using chemical or aerosol cleaning fluids to clean the product. Use a clean cloth slightly moistened with water.
- This product contains no parts repairable by the users. Contact VR-486 for services.
- Power off the Illuminator as soon as smoke or unusual odors are detected.
- Do not place the Illuminator on unsteady surfaces.
- Replacing or failing to properly install the waterproof components, e.g., cables or cable glands, will void our IP67 warranty.
- Refer to your datasheet for the operating temperature.
- Do not touch the Illuminator during a lightning storm.

# Mechanical Drawings

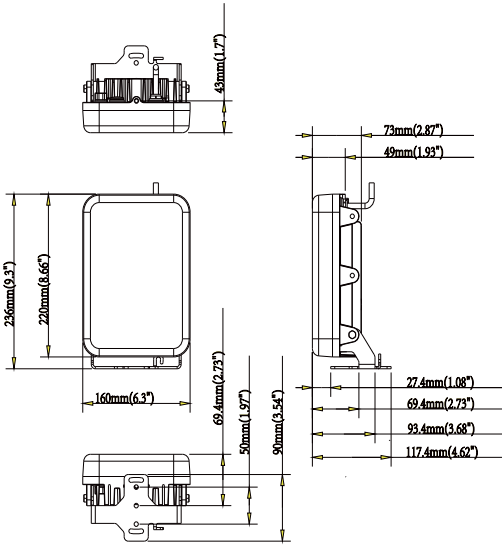

# Standard Small U bracket

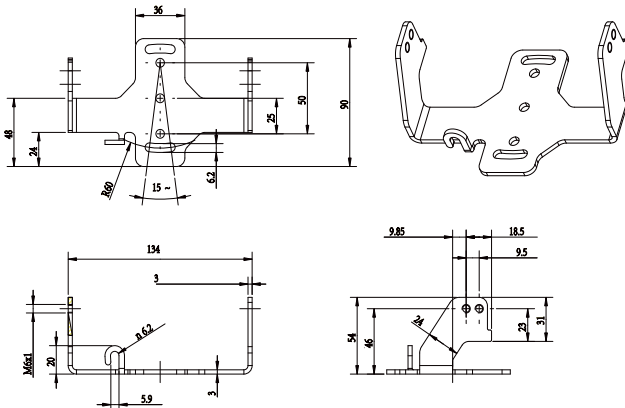

# 1 Hardware Overview

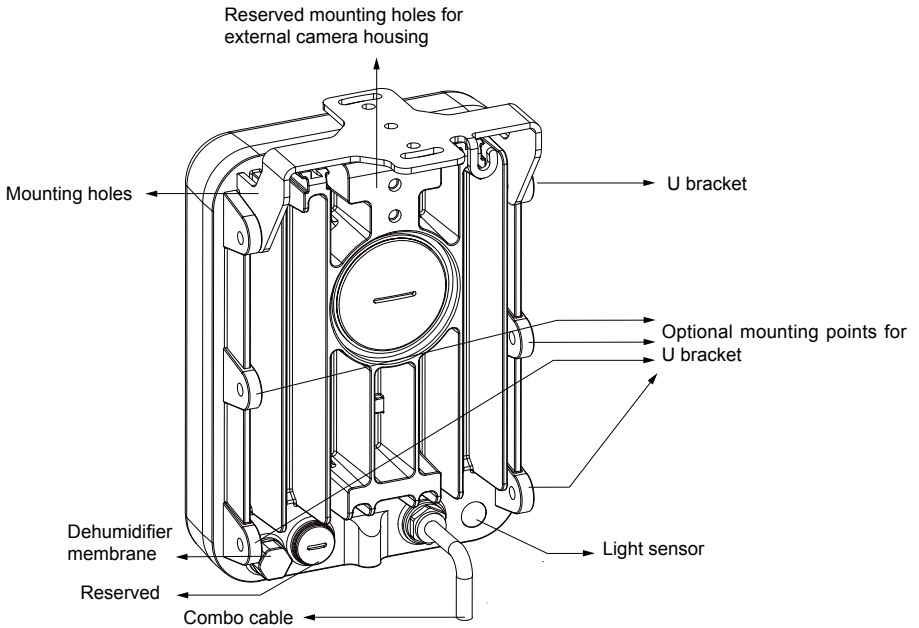

**Unit Weight:** 2.1KG.

**Max. Project Area:** 34684.7mm<sup>2</sup>.

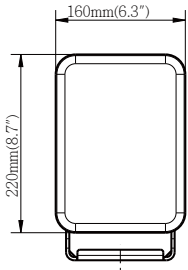

## Using the Remote Controller

### Beam angle selectors

#### Only function in VR806 series

These buttons provide quadruple proportions of adjustable angles from the narrowest, 33%, 66%, to the widest. These angles vary with different models. When a beam angle is selected, you can use the fine-tune buttons below to tune for a desired effect.

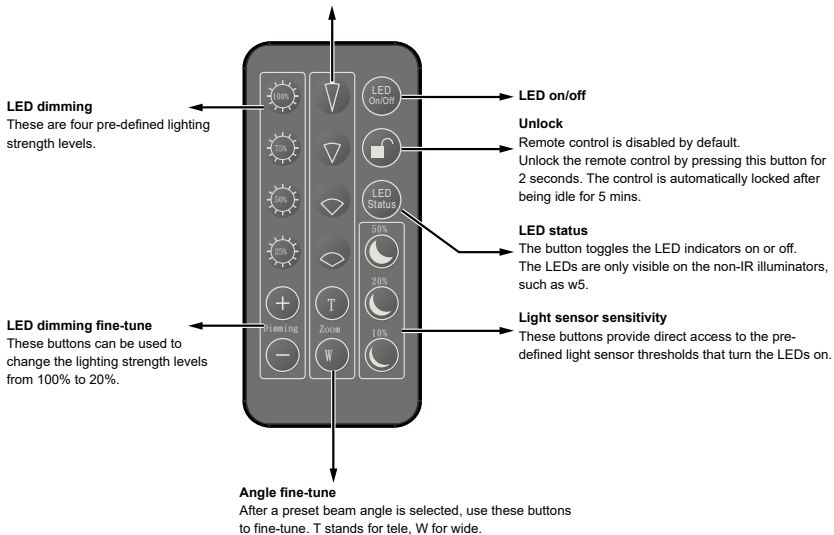

## Effective range for remote controller

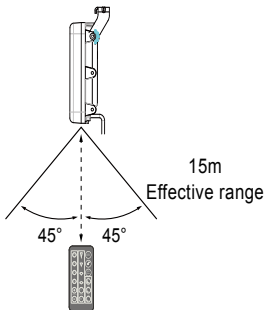

## II Installation

### Beam angle adjust:

You must first survey the installation site and determine the illumination distance.

#### VR-486 series

Use a coin or flat blade screwdriver to open the waterproof cover at the back of the illuminator.

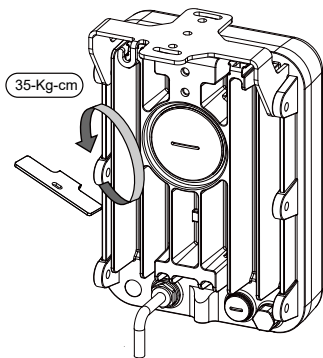

### 💡 Tips:

**You may forget your current beam angle configuration.** In this case, turn many full circles clockwise until the rotation resistance is felt (returns to the widest angle, reaches its mechanical stops), and then turn the selector counter-clockwise according to the angle listed on the tables. Each full circle corresponds to a preset beam angle.

Use the 4mm side of the allen wrench to turn the beam angle to an estimated illumination distance, e.g., 200 meters. See the tables on the next page for how to do it.

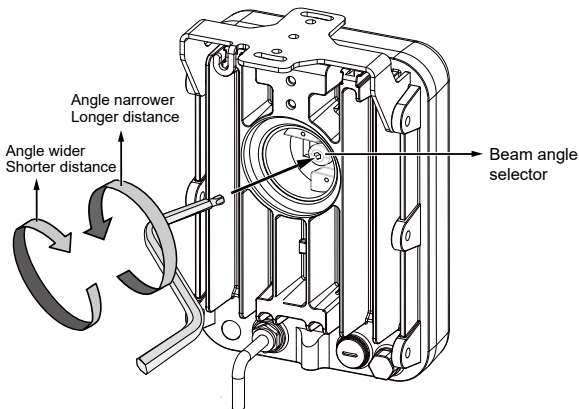





The factory default for the beam angle selector is always at the **Widest** angle. When you turn the selector many rounds to its widest or the narrowest position, a **rotation resistance** can be felt. That means the mechanical stop is reached, and you should not use more force.

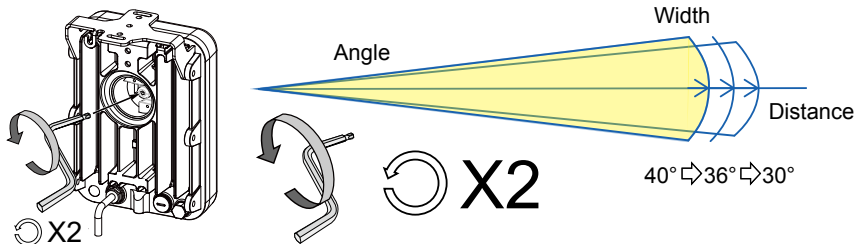

Refer to the tables below for the configurable IR light **beam angles** and the number of **full circles** needed to change to the preferred beam angles. Each full circle corresponds to a preset beam angle.



For example, if you need to change VR-486-1040's beam angle to 30° (127m), turn the beam angle selector **Counter-clockwise 2 full circles**. If you are at the narrowest angle (10°) and prefer to turn to 24°, turn 3 full circles clockwise. When done, install the waterproof cover.





VR-486-1040								
Rotate direction	Full circle	Beam angle	Single mount		Double mount		Triple mount	
			Distance(m)	Width(m)	Distance(m)	Width(m)	Distance(m)	Width(m)
 Counter-clockwise Narrower   Clockwise Wider	0	40°	100	72.8	141.4	102.9	173.2	126.1
	1	36°	107	69.5	151.3	98.3	185.3	120.4
	2	30°	127	68.1	179.6	96.3	220.0	117.9
	3	27°	137	65.8	193.7	93.0	237.3	113.9
	4	24°	150	63.8	212.1	90.2	259.8	110.4
	5	16°	206	57.9	291.3	81.9	356.8	100.3
	6	15°	215	56.6	304.1	80.1	372.4	98.1
7	10°	250	43.7	353.6	61.9	433.0	75.8	



VR-486-2040								
Rotate direction	Full circle	Beam angle	Single mount		Double mount		Triple mount	
			Distance(m)	Width(m)	Distance(m)	Width(m)	Distance(m)	Width(m)
 Counter-clockwise Narrower   Clockwise Wider	0	40°	120	87.4	169.7	123.5	207.8	151.3
	1	36°	125	81.2	176.8	114.9	216.5	140.7
	2	29°	150	77.6	212.1	109.7	259.8	134.4
	3	27°	158	75.9	223.4	107.3	273.7	131.4
	4	20°	200	70.5	282.8	99.7	346.4	122.2



VR-486-4080								
Rotate direction	Full circle	Beam angle	Single mount		Double mount		Triple mount	
			Distance(m)	Width(m)	Distance(m)	Width(m)	Distance(m)	Width(m)
 Counter-clockwise Narrower   Clockwise Wider	0	80°	60	100.7	84.9	142.4	103.9	174.4
	1	77°	62	98.6	87.7	139.5	107.4	170.8
	2	74°	64	96.5	90.5	136.4	110.9	167.1
	3	66°	67	87.0	94.8	123.1	116.0	150.7
	4	63°	69	84.6	97.6	119.6	119.5	146.5
	5	60°	71	82.0	100.4	115.9	123.0	142.0
	6	55°	75	78.1	106.1	110.4	129.9	135.2
	7	52°	79	77.1	111.7	109.0	136.8	133.5
	8	50°	82	76.5	116.0	108.2	142.0	132.5
	9	45°	86	71.2	121.6	100.8	149.0	123.4
10	40°	90	65.5	127.3	92.7	155.9	113.5	



VR-486-90120								
Rotate direction	Full circle	Beam angle	Single mount		Double mount		Triple mount	
			Distance(m)	Width(m)	Distance(m)	Width(m)	Distance(m)	Width(m)
 Counter-clockwise Narrower   Clockwise Wider	0	120°	45	155.9	63.6	220.5	77.9	270.0
	1	105°	50	130.3	70.7	184.3	86.6	225.7
	2	90°	55	110.0	77.8	155.6	95.3	190.5

VR-486-180					
Rotate direction	Full circle	Beam angle	Single mount	Double mount	Triple mount
			Distance(m)	Distance(m)	Distance(m)
Fixed angle	N/A	180°	40	56.6	69.3

VW-486-1040								
Rotate direction	Full circle	Beam angle	Single mount		Double mount		Triple mount	
			Distance(m)	Width(m)	Distance(m)	Width(m)	Distance(m)	Width(m)
 Counter-clockwise Narrower   Clockwise Wider	0	40°	100	72.8	141.4	102.9	173.2	126.1
	1	36°	107	69.5	151.3	98.3	185.3	120.4
	2	30°	127	68.1	179.6	96.3	220.0	117.9
	3	27°	137	65.8	193.7	93.0	237.3	113.9
	4	24°	150	63.8	212.1	90.2	259.8	110.4
	5	16°	206	57.9	291.3	81.9	356.8	100.3
	6	15°	215	56.6	304.1	80.1	372.4	98.1
7	10°	250	43.7	353.6	61.9	433.0	75.8	

VW-486-2040								
Rotate direction	Full circle	Beam angle	Single mount		Double mount		Triple mount	
			Distance(m)	Width(m)	Distance(m)	Width(m)	Distance(m)	Width(m)
 Counter-clockwise Narrower  Clockwise Wider	0	40°	120	87.4	169.7	123.5	207.8	151.3
	1	36°	125	81.2	176.8	114.9	216.5	140.7
	2	29°	150	77.6	212.1	109.7	259.8	134.4
	3	27°	158	75.9	223.4	107.3	273.7	131.4
	4	20°	200	70.5	282.8	99.7	346.4	122.2

VW-486-4080								
Rotate direction	Full circle	Beam angle	Single mount		Double mount		Triple mount	
			Distance(m)	Width(m)	Distance(m)	Width(m)	Distance(m)	Width(m)
 Counter-clockwise Narrower  Clockwise Wider	0	80°	60	100.7	84.9	142.4	103.9	174.4
	1	77°	62	98.6	87.7	139.5	107.4	170.8
	2	74°	64	96.5	90.5	136.4	110.9	167.1
	3	66°	67	87.0	94.8	123.1	116.0	150.7
	4	63°	69	84.6	97.6	119.6	119.5	146.5
	5	60°	71	82.0	100.4	115.9	123.0	142.0
	6	55°	75	78.1	106.1	110.4	129.9	135.2
	7	52°	79	77.1	111.7	109.0	136.8	133.5
	8	50°	82	76.5	116.0	108.2	142.0	132.5
	9	45°	86	71.2	121.6	100.8	149.0	123.4
10	40°	90	65.5	127.3	92.7	155.9	113.5	

VW-486-90120								
Rotate direction	Full circle	Beam angle	Single mount		Double mount		Triple mount	
			Distance(m)	Width(m)	Distance(m)	Width(m)	Distance(m)	Width(m)
 Counter-clockwise Narrower  Clockwise Wider	0	120°	45	155.9	63.6	220.5	77.9	270.0
	1	105°	50	130.3	70.7	184.3	86.6	225.7
	2	90°	55	110.0	77.8	155.6	95.3	190.5

## VR-806 series

Use the remote controller to adjust the beam angle.

The factory default for the beam angle selector is always at the **Widest** angle.

Refer to the tables below for the configurable IR light **beam angles** and the definitions of the remote controller buttons. Each button changes to a preset beam angle.

### Example:

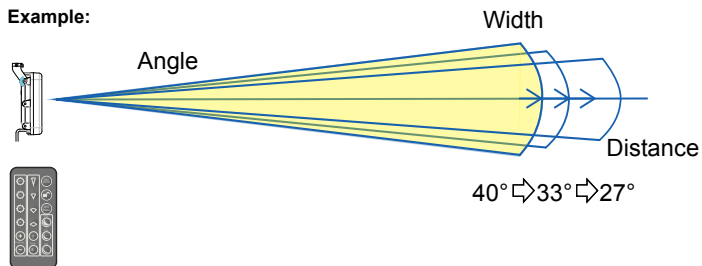

VR-806-1040							
Button	Beam angle	Single mount		Double mount		Triple mount	
		Distance(m)	Width(m)	Distance(m)	Width(m)	Distance(m)	Width(m)
	40°	140	101.9	198.0	144.1	242.5	176.5
	30°	178	95.4	251.7	134.9	308.3	165.2
	20°	250	88.1	353.5	124.7	433.0	152.6
	10°	350	61.2	495.0	86.6	606.2	106.1

VR-806-2040							
Button	Beam angle	Single mount		Double mount		Triple mount	
		Distance(m)	Width(m)	Distance(m)	Width(m)	Distance(m)	Width(m)
	40°	170	123.7	240.4	175.0	294.4	214.3
	33°	190	112.6	268.7	159.2	329.1	195.0
	27°	221	106.1	312.5	150.1	382.8	183.8
	20°	280	98.7	396.0	139.6	485.0	171.0

## Cable Pinouts



Name	Color	Gauge	Description
V+	Red	(20AWG)	Power input
V-	Black	(20AWG)	24V DC±10% 24V AC±10% (50/60Hz)
DI+	Green	(26AWG)	LED ON/OFF control * Dry contact Logic level 1(Open) = LED off Logic level 0(Close to GND) = LED on * Wet contact Logic level 1: 4V~40 V = LED off Logic level 0: 0.8V MAX = LED on
DI-	Yellow	(26AWG)	Ground
DO+	Purple	(26AWG)	Light sensor status output 1. Open = Day 2. Short = Night (300 lux for IR ON)
DO-	Blue	(26AWG)	Ground
RS485+	Orange	(26AWG)	RS485 interface control
RS485-	Brown	(26AWG)	

## Coordination with Cameras via the DI and DO Pins

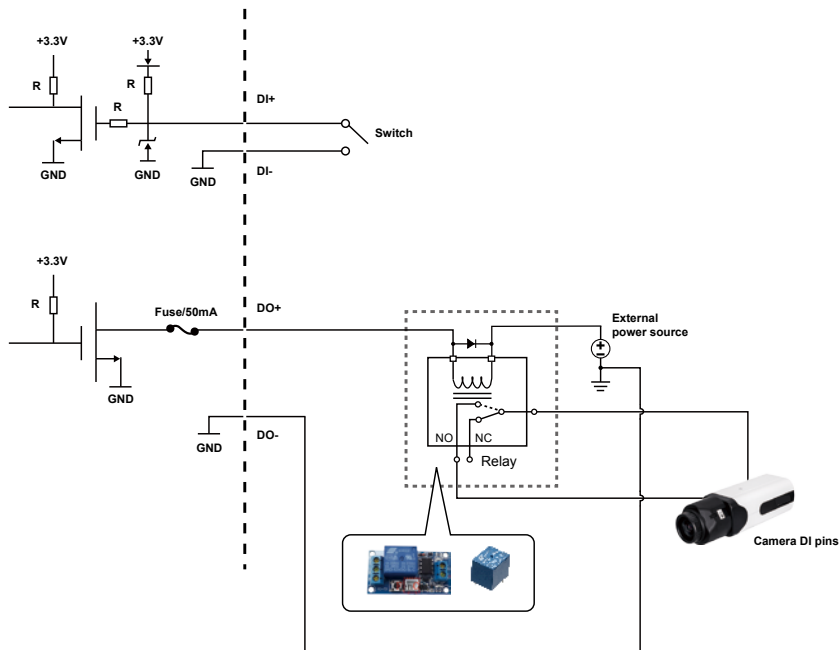

### IR LED ON/OFF control (Green & Yellow wires)

This mode means that illuminator On/Off control is triggered by camera or other alarm system. Users can decide using the appropriate dry/wet contacts depending on wiring condition.

DI+: Green = TTL + voltage

DI-: Yellow = TTL - voltage (GND)

#### \* Dry contact

Logic level 1 (Open) = LED off

Logic level 0 (Close to GND) = LED on

#### \* Wet contact

Logic level 1: 4V~40 V = LED off

Logic level 0: 0.8V MAX = LED on

## Light sensor status output (Purple & Blue wires)

This mode means that camera Day/Night mode switching is coordinated with and is triggered by the illuminator's light sensor via the DO(Digital output) connection (connected to the camera's DI pins).

Users can configure the camera configuration to control the corresponding illuminator On/Off status.

DO+: Purple= Open drain output, 45V Max. (current must be under 100mA)

DO-: Blue = GND

Light sensor status output

1. Open = Day
2. Short = Night (lower than 300 lux for IR to turn ON)

## Stand-alone illuminator mode

This mode means that the illuminator's On/Off control is triggered by its light sensor, in the case, the default wiring is connecting the green wire with purple wire.

Some cameras have related settings that need the inter-connection with the illuminator. For example, some cameras come with an IR cut filter that need to be turned off when entering night mode; or, automatically turn on the adjacent illuminator when entering night mode.

The screenshot shows a web-based configuration interface for a camera. The left sidebar contains a navigation menu with categories: System, Media, Network, Security, PTZ, Event, Applications, Recording, and Local storage. The 'Media' section is expanded, and the 'Image' sub-section is selected. The main content area is titled 'Media > Image' and contains several tabs: 'General settings', 'Image settings', 'Exposure', and 'Privacy mask'. The 'Image settings' tab is active. Under 'Video settings', there are fields for 'Video title', a checked box for 'Show timestamp and video title in video and snapshots', a dropdown for 'Position of timestamp and video title on image' (set to 'Top'), a dropdown for 'Timestamp and video title font-size' (set to '30'), a dropdown for 'Video font (tff)' (set to 'Default') with an 'Upload' button, radio buttons for 'Color' (set to 'Color'), and radio buttons for 'Power line frequency' (set to '50 Hz'). Under 'Day/Night settings', there is a checked box for 'Turn on external IR illuminator in night mode' and a dropdown for 'IR cut filter' with options: 'Auto mode', 'Day mode', 'Night mode', 'Synchronize with digital input', and 'Schedule mode'.



# Mounting Configuration & Dimensions

## Swivel Positions and Directions

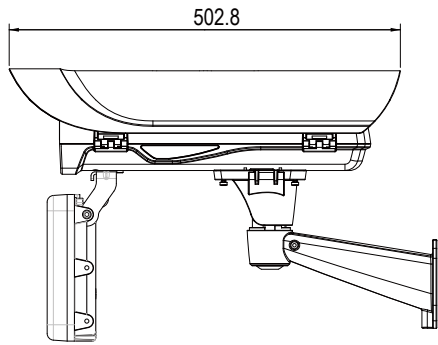
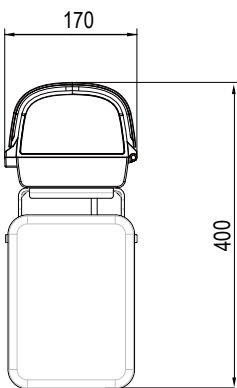
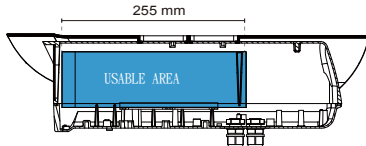
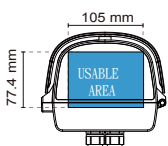
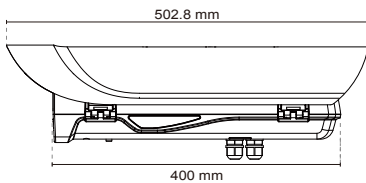
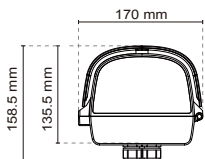

## IV Installation

1. Install the wall-mount bracket to a preferred location at your installation site. Drill mounting holes and a cable routing hole (if preferred) on a wall. Install the bracket. Prepare and route the wiring, Ethernet and 24V power source.

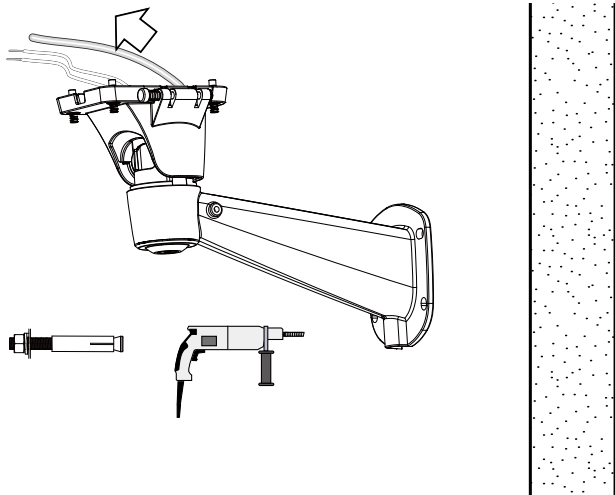

2. Install the IR illuminator to the bottom of the housing. Attach the included grip stricker to the U bracket.

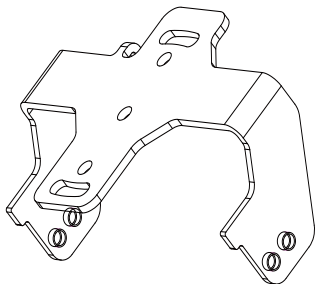

**3.** Secure the U bracket to the IR illuminator using the included hex screws.

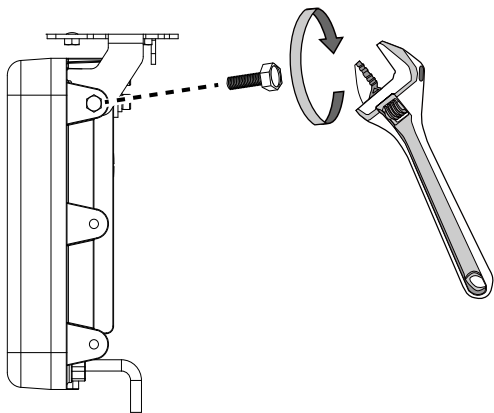

**4.** Flip the housing over and place it on a clean, stable surface. Secure the IR illuminator to the bottom of the housing using the included wrench and a hex socket screw.

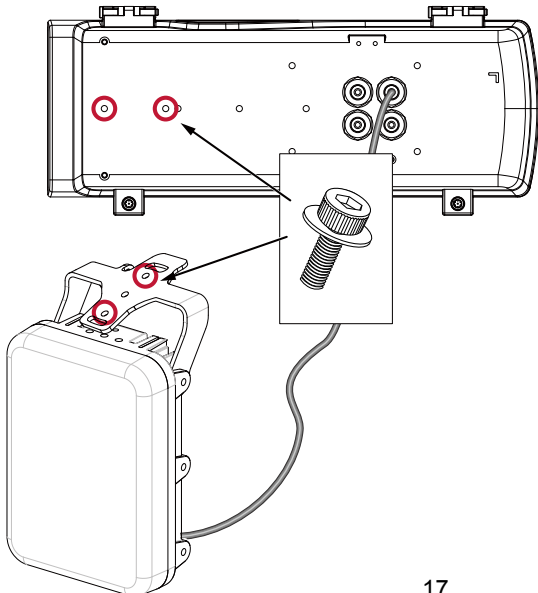

5. You can turn the IR illuminator so that its flat side is parallel with the housing, and that you can turn the assembly over and work on the inside of the housing. Put a foam pad below before you work on the wiring to avoid scratching the surface.

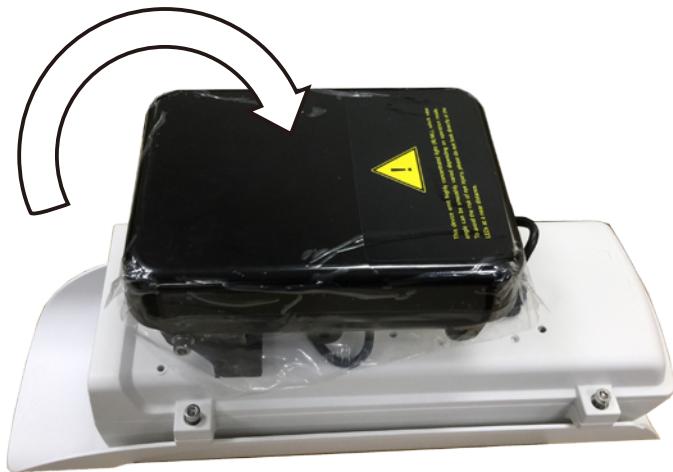

6. Prepare power wires, a ground wire, and a CAT5e Ethernet cable. Pass them through the M16 waterproof connectors under the housing.

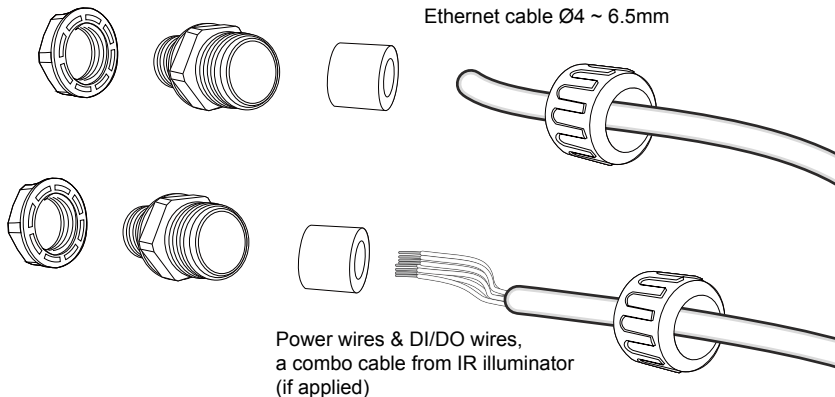

You may need to remove the RJ45 connector, and use a crimping tool to connect the Ethernet wires to an RJ45 connector inside the enclosure. Use an Ethernet cable of the width of 4 ~ 6.5mm.

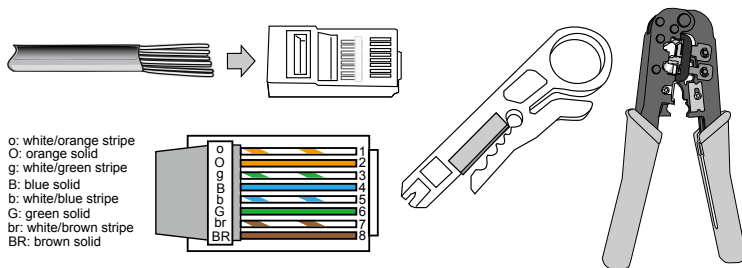

**7.** When done, tighten up and install the waterproof connectors.

**8.** Assemble the camera components, e.g., the CS ring and lens module. Secure the mounting plate to the bottom of the camera (the label side) using the included screw.

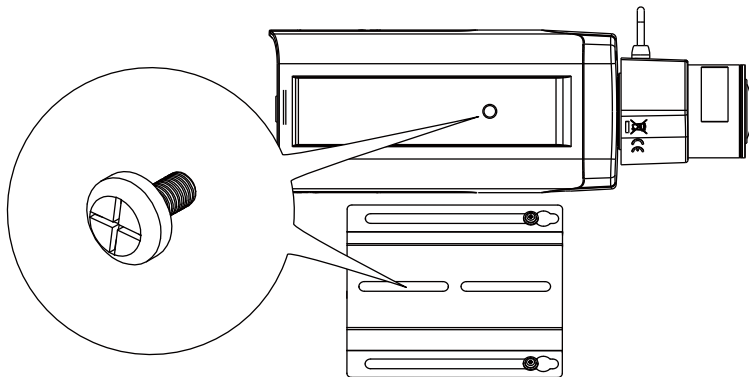

There is a plastic mount pad in the package. You do not need the mounting pad using the AETEK camera.

---

This page is intentionally left blank.